

LITTLE WONDER

PRO VAC

MODEL:

5612-00-01

(S/N 1140043719 and above)



MAN 4170967
Rev. A 05-2014

OPERATOR'S / PARTS MANUAL

CALIFORNIA

Proposition 65 Warning

Diesel engine exhaust and some of its constituents are known to the State of California to cause cancer, birth defects and other reproductive harm.



WARNING

The engine exhaust from this product contains chemicals known to the State of California to cause cancer, birth defects or other reproductive harm.

CALIFORNIA

Proposition 65 Warning

Battery posts, terminals, wiring insulation, and related accessories contain lead and lead compounds, chemicals known to the State of California to cause cancer and birth defects or other reproductive harm.

WASH HANDS AFTER HANDLING.

LITTLE WONDER PRO VAC



IMPORTANT MESSAGE

On behalf of everyone at Little Wonder, we would like to thank you for your purchase of a Little Wonder Pro Vac. This professional vac was designed to the highest standards to ensure you many hours of uninterrupted service.

This manual provides the information necessary for safe and efficient operation and service. For your safety, it is critically important that you read and understand this entire manual before operating your vacuum.

LITTLE WONDER
SCHILLER GROUNDS CARE, INC.
1028 STREET ROAD, P.O. BOX 38
SOUTHAMPTON, PA 18966

TABLE OF CONTENTS	FIGURES	PAGE
SAFETY.....		4-7
LABELS.....		8, 9
SET-UP INSTRUCTIONS.....		10, 11
CONTROLS.....		12
OPERATION.....		13
FAN REMOVAL.....		14
MAINTENANCE / STORAGE.....		15
PARTS SECTION.....		17
PARTS ASSEMBLY.....		18, 19
COLLECTOR ASSEMBLY.....		20, 21
LINER ASSEMBLY.....		22, 23
NOZZLE ASSEMBLY.....		24, 25
WARRANTY.....		BACK COVER

NOTICE !!!

Unauthorized modifications may present **extreme** safety hazards to operators and bystanders and could also result in product damage.

Schiller Grounds Care, Inc. strongly warns against, rejects and disclaims any modifications, add-on accessories or product alterations that are not designed, developed, tested and approved by Schiller Grounds Care, Inc. Engineering Department. Any Schiller Grounds Care, Inc. product that is altered, modified or changed in any manner not specifically authorized after original manufacture-including the addition of "after-market" accessories or component parts not specifically approved by Schiller Grounds Care, Inc.-will result in the Schiller Grounds Care, Inc. Warranty being voided.

Any and all liability for personal injury and/or property damage caused by any unauthorized modifications, add-on accessories or products not approved by Schiller Grounds Care, Inc. will be considered the responsibility of the individual(s) or company designing and/or making such changes. Schiller Grounds Care, Inc. will vigorously pursue full indemnification and costs from any party responsible for such unauthorized post-manufacture modifications and/or accessories should personal injury and/or property damage result.



This symbol means:
ATTENTION!
BECOME ALERT!

Your safety and the safety of others is involved.

Signal word definitions:

The signal words below are used to identify levels of hazard seriousness. These words appear in this manual and on the safety labels attached to Schiller Grounds Care, Inc. machines. For your safety and the safety of others, read and follow the information given with these signal words and/or the symbol shown above.

⚠ DANGER

DANGER indicates an imminently hazardous situation which, if not avoided, **WILL** result in death or serious injury.

⚠ WARNING

WARNING indicates a potentially hazardous situation which, if not avoided, **COULD** result in death or serious injury.

⚠ CAUTION

CAUTION indicates a potentially hazardous situation which, if not avoided, **MAY** result in minor or moderate injury. It may also be used to alert against unsafe practices or property damage.

CAUTION

CAUTION used without the safety alert symbol indicates a potentially hazardous situation which, if not avoided, **MAY** result in property damage.

Schiller Grounds Care, Inc.

1028 Street Road
Southampton, PA 18966 U.S.A
Phone: 215-357-5110
Fax: 215-357-8045

MODEL NUMBER

SERIAL NUMBER

MODEL NUMBER: This number appears on sales literature, technical manuals and price lists.

SERIAL NUMBER: This number appears only on your mower. It contains the model number followed consecutively by the serial number. Use this number when ordering parts or seeking warranty information.

MACHINE PREPARATION

Operator preparation and training

Read the Operation & Safety Manual

- If an operator or mechanic cannot read English, it is the owner's responsibility to explain this material to them. If any portion of this material is unclear, contact your factory representative for clarification.
- Become familiar with the safe operation of the equipment, operator controls and safety signs. Be prepared to stop the engine quickly in an emergency. Do not operate or allow another person to operate this machine if there are any questions about safety.
- All operators and mechanics should be trained. The owner is responsible for training the users.
- Wear appropriate clothing, including safety goggles or safety glasses with side shields when operating. Wear substantial footwear. Do not operate barefoot or wearing open sandals. Long hair, loose clothing or jewelry may get tangled in moving parts.
- Wear appropriate hearing protection.
- Wear safety glasses.
- Avoid contact with and inhalation of harmful fluids, gases, mists, fumes and dust.
- Wear dust mask to avoid breathing dust.
- Never allow children, unskilled or improperly trained people to operate this equipment. Local regulations can restrict the age of the operator.
- Keep warning labels and this operator's manual legible and intact. Replacement labels and manuals are available from the factory.
- Do not operate machine while under the influence of drugs or alcohol, or any other condition of impairment.
- The owner/user can prevent and is responsible for accidents or injuries occurring to themselves, other people or property.

SITE PREPARATION AND CIRCUMSTANCES

- Evaluate the terrain to determine how to safely perform the job. Only use accessories and attachments approved by the manufacturer.
- Be sure the area is clear of pets and people, especially young children. Never assume they will remain where you last saw them. Stop the machine if any enter the area.

MULTIPLE OPERATORS

- Keep a safe distance between operators when working together.

MACHINE PREPARATION

- Do not tamper with or defeat safety devices. Keep guards, shields and interlock safety devices in place and in proper working condition. They are for your protection.
- Keep all fasteners such as nuts, bolts and pins well secured.
- Verify that machine and attachments, if any, are in good operating condition.

OPERATING SAFELY

IN GENERAL

- Use extra care when loading or unloading the machine into a trailer or truck.
- Do not run the engine in an enclosed area where dangerous carbon monoxide fumes can collect.
- Never leave a running machine unattended. Always stop engine when leaving the operator position.
- Do not blow towards people, cars, windows, or other items which could be injured or damaged by the blown debris.
- Keep hands away from the vacuum air intake and outlet.

STARTING

- Start according to instructions in this manual or on the machine.
- Do not change engine governor settings or overspeed the engine. Operating the engine at excessive speed can increase the hazard of personal injury.



OPERATING ON SLOPES

- Slopes are a major factor in loss of control and tip over accidents that sometimes lead to severe injury or death. All slopes require extra caution.
- Before operating on slopes, evaluate the risks involved.
- Do not operate on slopes if uneasy or uncertain. Ultimate responsibility for safe operation on slopes rests with the operator.
- Do not operate on steep slopes. Poor footing could cause a slip and fall accident.
- Keep all movement on slopes slow and gradual.
- Do not operate near drop-offs, ditches or embankments. You could lose your footing or balance.
- Do not turn on slopes unless necessary, and then turn slowly and downhill when possible.
- Be sure of your footing on slopes.
- Watch for holes, ruts, bumps, rocks and other hidden objects. Uneven terrain could cause a slip and fall accident. Tall grass can hide objects.

INTERRUPTING OPERATION

- Before leaving the operator's position:
 - Park on level ground.
 - Shut off the engine.
- Stop the engine, and wait until the fan stops moving:
 - before refueling;
- Stop the engine, and disconnect the spark plug wire(s):
 - before clearing blockages;
 - before checking, cleaning or working on the machine;
 - if the machine begins to vibrate abnormally: shut off machine immediately. Inspect and have repairs made as needed before restarting;
 - except for repairs or adjustments as specifically noted, such as for carburetor adjustment, where the engine must be running. Keep hands and feet clear of moving parts in these circumstances.
- Allow the fan to come to a complete stop when stopping operation to clear blockages, unclog, inspect the machine, do maintenance or repair.
- Reduce the throttle setting during engine shut-down and, if the engine is provided with a shut-off valve, turn the fuel off at the conclusion of operation.

MAINTENANCE SAFETY

In general

- Maintain machine according to manufacturer's schedule and instructions for maximum safety and best results.
- Park machine on level ground.
- Never allow untrained personnel to service machine.
- Guards should only be removed by a qualified technician for maintenance or service.
- Adjust or repair only after the engine has been stopped and the fan has stopped moving.
- Disconnect spark plug wire(s) before doing any maintenance.
- Replace parts if worn, damaged or faulty. For best results, always replace with parts recommended by the manufacturer.
- Do not dismantle the machine without releasing or restraining forces which may cause parts to move suddenly.
- Provide adequate support, e.g. jack stands for lifted machine or parts if working beneath.
- Do not put hands or feet near or under rotating parts.
- Clean up spilled oil or fuel thoroughly.
- Replace faulty mufflers.
- To reduce fire hazards, keep the engine, muffler, and fuel storage area free of grass, leaves, debris buildup or grease.

Fans

Do not straighten or weld fans. Replace damaged or failed fans.

Fuel

- Petrol (gasoline) and diesel fuels are flammable; petrol (gasoline) vapors are explosive. Use extra care when handling.
- Store only in containers specifically designed for fuel.



- When refueling or checking fuel level:
 - Stop the engine and allow to cool;
 - Do not smoke;
 - Refuel outdoors only;
 - Use a funnel;
 - Do not overfill;
 - If fuel is spilled, do not attempt to start the engine until the spill is cleaned up and vapors have cleared.
- Replace caps on fuel containers and tanks securely.

Sparks from static electricity can start fires or cause explosions. Flowing fuel can generate static electricity. To prevent static electricity sparks:

- Keep containers electrically grounded. Do not fill containers in a vehicle or on a truck or trailer bed with a plastic liner. Fill containers on the ground away from the vehicle.
- When practical, remove petrol (gasoline) powered equipment from the truck or trailer and refuel it on the ground. If equipment must be refueled on the truck or trailer, refuel from a portable container rather than a dispenser nozzle.
- Keep the dispenser nozzle in contact with the rim of the fuel tank or container opening until fueling is complete. Do not use a nozzle lock-open device.
- If petrol (fuel) is spilled on clothing change it immediately.

STORAGE SAFETY

- Stop the engine and allow to cool before storing.
- Drain the fuel tank outdoors only.
- Store fuel in an approved container in a cool, dry place.
- Keep the machine and fuel containers in a locked storage place to prevent tampering and to keep children from playing with them.
- Do not store the machine or fuel container near an open flame, spark, or appliance, such as a water heater, or a pilot light.
- Keep petrol (gasoline) storage area free of grass, leaves and excessive grease to reduce fire hazard.
- Clean grass and debris from cutting units, drives, mufflers and engine to help prevent fires.

LITTLE WONDER®

**Pro
Vac**

⚠ DANGER



Rotating Blades
CUT / AMPUTATION HAZARD

- Keep hands out of fan housing.
- Stop engine and remove spark plug wire before cleaning or servicing.
- Keep large and/or hard objects from entering machine.
- Do not operate without nozzle or intake hose and bag in place.

4170472



UNPACKING THE UNIT

1. Remove Collector assembly, Nozzle assembly, and debris bag from the top section of the package.
2. Remove cardboard insert.
3. Cut away short side of the box and fold down.
4. Roll Pro Vac base unit out of the box.

ASSEMBLY (See Figures on page 11)

1. Attach the **collector assembly** to the base unit:
 - Bolt the collector assembly to the frame with 4 sets of bolts, nuts, and 3 washers. Attach rope guide with upper right bolt.
 - Slide the rectangular end of the collector over the housing and mount the flange with 2 sets of washers and nuts.
2. Attach the throttle cable bracket to the handle with a 1/4-20 thread rolling screw A. Tighten until snug, but do not overtighten. Install throttle cable assembly to handle with 1/4-20x2 bolt, 2 washers, and 1/4 nylon locknut.
 - Secure throttle cable to handle with **cable ties** in 2 places.
3. Install the **band clamp** into the **debris bag** (wear gloves when handling band clamp):
 - Slide the bracket end of the band clamp through the left side opening of the sleeve on the debris bag until it emerges from the right side.
 - Feed the tail end of the band (on the clasp side) behind the bracket in the sleeve.
 - Pinch the wire form on the clasp together and connect it through 2 holes in the adjustment bracket such that it will close tightly over the collector.
4. Connect the **debris bag** by placing it over the bottom lip of the **collector** and closing the clasp to secure the bag. Adjust the clasp wire form to the appropriate hole position on the bracket to insure a tight fit. If the bag will not fit tight within the range of the 3 adjustment holes, insert the bag **seal strap**:
 - Unhook the wire form from the bracket.
 - Pull the tail end of the band back out from behind the bracket.
 - Feed one end of the **seal strap** behind the metal band and through the channel to the other side.
 - Tuck the other end of the **seal strap** behind the bracket (overlapping the lead end of the **seal strap**).
 - Feed the tail end of the **band clamp** behind the bracket (overlap the **seal strap**).
 - Connect the wire form to the appropriate holes in the bracket and secure the debris bag to the collector.

5. Attach **nozzle assembly** to base unit:
 - Attach one end of the **hose** to the nozzle assembly with the **bridge clamp assembly**.
 - Slide the other end of the **hose** over the edge of the inlet on the **front plate**.
 - Hook one side of the **nozzle bracket** over the front axle.
 - Bend the other end of the nozzle bracket inward to hook it over the axle and engage the pins on the **wheel bracket** with the slots on the **nozzle bracket**.
 - Secure the hose to **front plate** inlet with the **bridge clamp**.
 - Attach the **nozzle cable** end fitting through the hole in the **nozzle bracket**.
6. To remove **nozzle assembly** (for purposes of storage, or clearing blockages):
 - Turn engine off and disconnect spark plug.
 - Loosen **hose clamp** on the **front plate** with flathead screwdriver or 5/16 wrench.
 - Slide hose off of **front plate** inlet.
 - Bend one side of **nozzle bracket** inward and twist the **assembly** to remove the hook from the axle.
 - Twist back and lift to remove the other side of **nozzle bracket** from the axle.

LIFTING LUG

The Little Wonder Pro Vac includes a convenient lifting lug **A** on top of the fan housing that can be used to lift the unit. This lug can only hold up to a total of 250 lbs (115 kg).

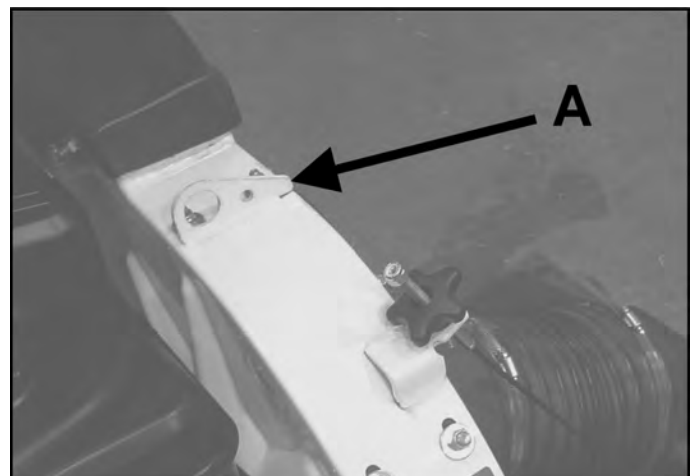

LITTLE WONDER PRO VAC

SET-UP INSTRUCTIONS

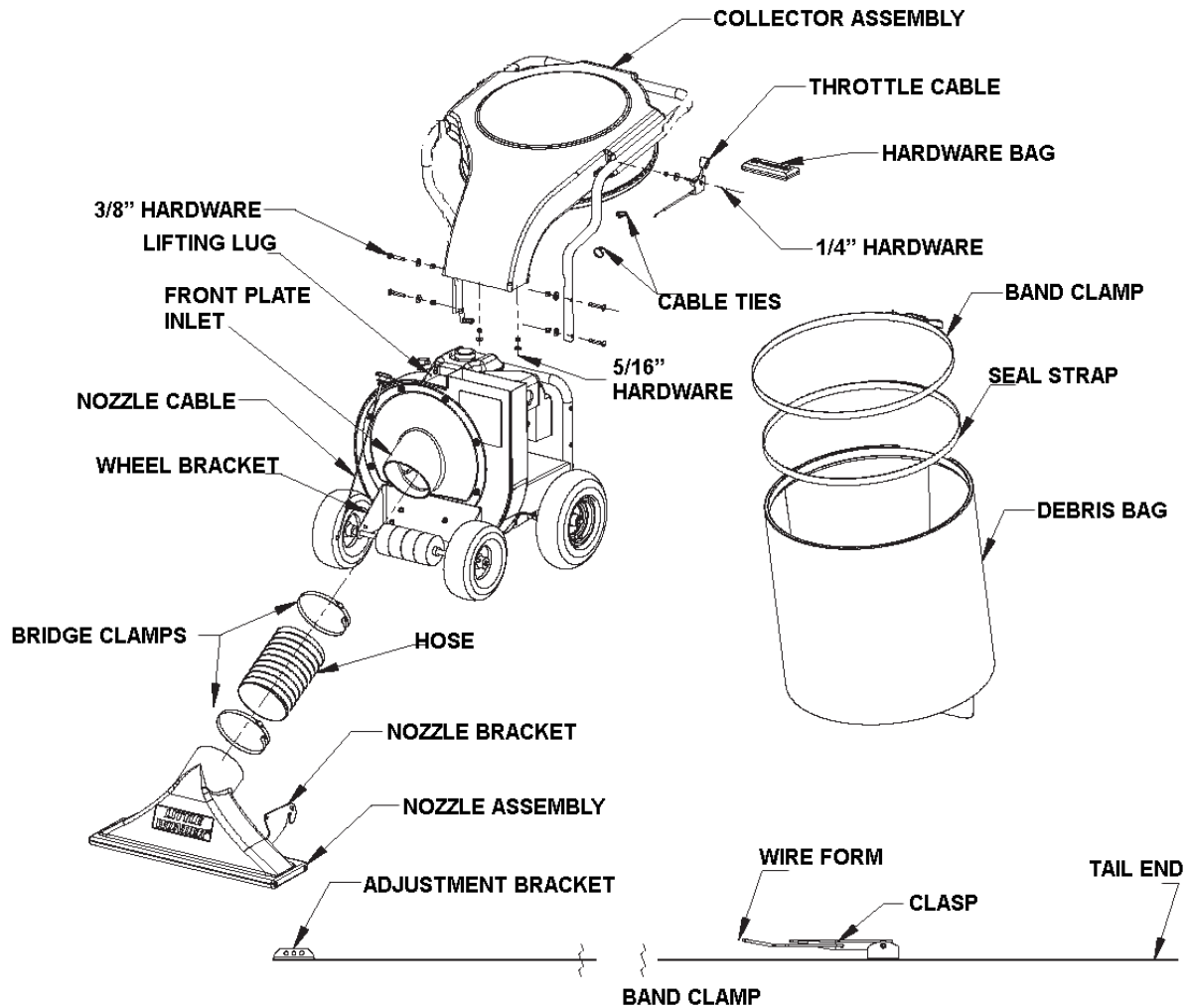

ROPE GUIDE

Attach the rope guide with the upper right bolt. Pull the starter rope out and route it through the rope guide.



THROTTLE BRACKET ASSY.

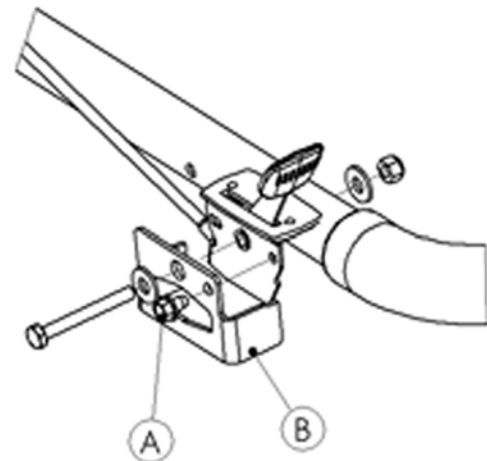

BEFORE STARTING THE ENGINE

1. Read the Operator Manual and Engine Manual. Become familiar with the controls, how each functions, and what it operates.
2. Check the engine oil level and add if necessary.
3. Fill the fuel tank with good quality, clean, unleaded regular gasoline (petrol). Use a funnel to avoid spilling.
4. Check that the bag is securely in place.
5. Select the height of the nozzle.

STARTING THE ENGINE

1. Open the fuel valve.
2. Move the choke lever to the "CHOKE" position for cold starts. (Choke may not be required to start a warm engine. Too much choke use may flood the engine and cause hard starting.)
3. Move the throttle to midway between the fast and slow positions.
4. Pull the recoil starter slowly until resistance is felt, then pull firmly to start the engine.
5. After the engine starts, slowly back the choke off until the engine runs with no choke at all.
6. Set the desired engine speed with the throttle.

VACUUMING

1. Adjust nozzle to select height by turning the nozzle control knob, secure position with wing nut.
2. Start the engine and push the vacuum over area to be cleared.

Examples of items suitable to be vacuumed:

- | | |
|------------------|-------------------------|
| -leaves | -dry mulch |
| -small twigs | -litter |
| -acorns | -thistles |
| -seed pods | -small cans and bottles |
| -grass clippings | -paper products |
| -straw | -styrofoam products |
| -wood chips | |

Examples of items/areas to avoid.

- excessively wet surfaces and debris
- gravel surfaces
- large hard objects
- rocks
- long fibrous materials (vines, ropes, string, etc.)

Do not force anything in to the vacuum. If an item is too large to fit, pick it up separately.

EMPTY DEBRIS BAG

1. Turn off the engine by moving the throttle to the "STOP" position. Let the engine come to a complete stop before removing the debris bag.
2. Roll vacuum to the unloading location.
3. Open the clasp on band clamp to release bag.
4. Avoid dragging the bag to prolong the bag life.
5. Empty the bag. Handle straps are located on the under side of the bag for aid in dumping content..
6. Reconnect the bag to the collector.

REMOVING BLOCKAGES / CLOGS

1. Turn off the engine by moving the throttle to the "STOP" position. Let the engine and fan come to a complete stop.
2. Remove spark plug wire.
3. Remove bag and/or hose and clear the blockage. Wear gloves as there may be sharp materials in the clog.
4. Reinstall the bag and/or hose.
5. Reconnect spark plug wire.

MAINTENANCE INSTRUCTIONS

Stop engine and remove the spark plug wire before performing any maintenance.

Keep the engine's cooling air intake clear of debris for best performance.

Keep all hardware tight.

Clean air cleaner daily. See engine manual for details.

Check oil level daily. Top off as needed.

After each use, run the vac with an empty bag to clear any material that may remain in the housing.

Change engine oil after the first 5 hours of operation. Then change as recommended by the engine manufacturer.

1. Remove drain plug and drain oil while engine is warm.
2. Replace drain plug, remove fill plug and fill with new oil. Little Wonder recommends SAE 30 oil whenever applicable.
3. Start and run engine for 30 seconds. Stop engine.
4. Wait 30 seconds, then re-check oil level.
5. Top off if necessary. See engine manual for details.

STORAGE

To prevent possible explosion or ignition of vaporized fuel, do not store equipment with fuel in tank or carburetor in an enclosure with open flame (for example, a furnace or water heater pilot).

Before the equipment is put into storage for any period exceeding 30 days, the following steps should be completed.

1. Drain all fuel from the fuel tank and fuel lines.
2. Start the engine and run until all the fuel is used from the carburetor float bowl and the engine stops.
3. While the engine is still warm, drain the crankcase oil and replace with the proper weight oil corresponding to the season the equipment will be next used.
4. Remove the spark plug and squirt a small amount of engine oil into the cylinder. Slowly pull the starter a few times to distribute oil in the cylinder and reinstall the spark plug.
5. Top off if necessary. See engine manual for details.

To put the equipment into service after an extended period of storage.

1. Check for loose parts and tighten if necessary.
2. Fill the fuel tank and then check the engine oil level.
3. Start the engine and check for fuel leaks. Repair any leaks before operating the unit.

PARTS ASSEMBLY

FIGURE 1

LITTLE WONDER PRO VAC

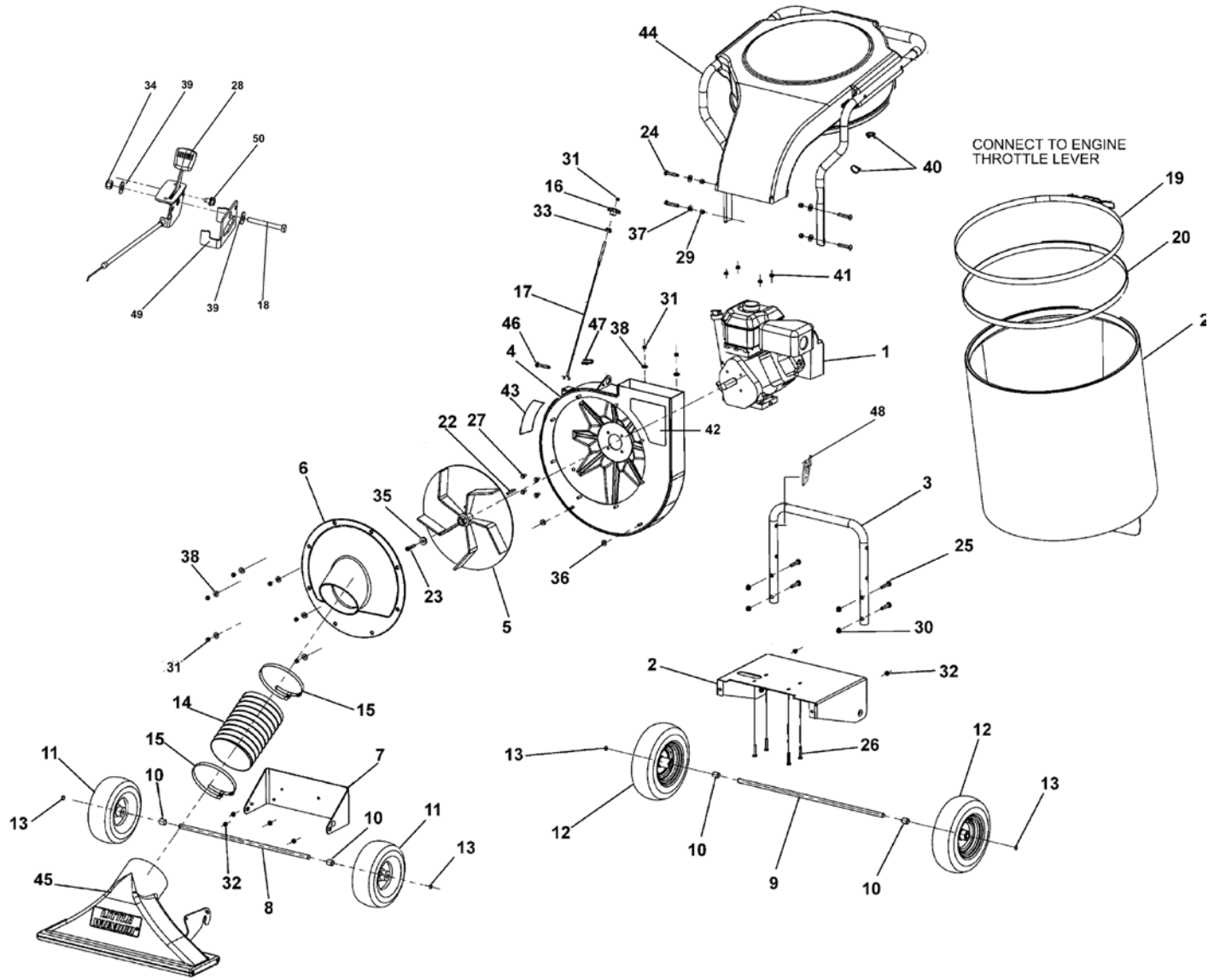

LITTLE WONDER PRO VAC

PARTS ASSEMBLY

FIGURE 1

ITEM	PART NO.	DESCRIPTION	QTY	ITEM	PART NO.	DESCRIPTION	QTY
1	4166004	ENGINE-6.5 HP VANGARD	1				
2	600180.17	DECK-PRO, 6HP	1				
3	600184.17	HANDLE MOUNT	1				
4	4171303	S-HOUSING VAC	1				
5	600114	IMPELLER-BALANCED	1				
6	600198	PLATE-FRONT	1				
7	600182.17	BRACKET-FRONT WHEELS	1				
8	600297	AXLE-FRONT	1				
9	600298	AXLE-REAR	1				
10	600137	SPACER-WHEEL	4				
11	4164205	WHEEL-10"	2				
12	4164204	WHEEL-12"	2				
13	600562	RETAINING RING E 5/8	4				
14	600102	HOSE-NOZZLE	1				
15	720420	BRIDGE CLAMP-HOSE	2				
16	600162	KNOB-NOZZLE CNTRL	1				
17	4165925	CABLE-NOZZLE VAC	1				
18	64123-113	BOLT-HEX, 1/4-20 X 2-1/4	1				
19	600176	CLAMP-BAND	1				
20	600196	BAG-SEAL STRAP	1				
21	600177	DEBRIS BAG	1				
22	64164-13	KEY-1/4" SQ X 2" LG	1				
23	64123-127	BOLT-3/8-24 X 1-3/4	1				
24	600504	BOLT-CRG 3/8-16 X 2-1/4	4				
25	64018-18	BOLT-CRG 3/8-16 X 2	4				
26	64262-009	BOLT-FLGHD 5/16-18 X 1-1/2	4				
27	910503	BOLT-5/16-24 X 3/4	4				
28	4166366-01	CABLE-THROTTLE	1				
29	64229-03	LOCKNUT-3/8-16	4				
30	64141-4	NUT-FLANGE 3/8-16	4				
31	64229-02	LOCKNUT-5/16-18	9				
32	64141-6	NUT-FL 5/16-18	6				
33	64214-01	NUT-WING 5/16-18	1				
34	64229-01	LOCKNUT-1/4-20	1				
35	910527	WASHER-FAN	1				
36	64163--46	WASHER-3/8 ID X 3/16 TH	4				
37	64163-31	WASHER-3/8	4				
38	64163-29	WASHER-25/64x1x12GA	10				
39	64163-55	WASHER-1/4	4				
40	720411	CABLE TIE-11-5/8 BLK	2				
41	64268-02	NUT-NYLON LOCK 5/16-18	4				
42	4170472	LABEL-INTAKE WARNING	1				
43	4166393	LABEL-WARNING MANUAL	1				
44	600101	ASSY-COLLECTOR	1				
45	600100	ASSY-NOZZLE	1				
46	64188-65	PIN-CLEVIS 1/4X.62	1				
47	64168-2	COTTER-HAIRPIN .08X1.19	1				
48	4166365.17	WLDMT-ROPE GUIDE	1				
49	4166661.7	BRKT-THROTTLE, VAC	1				
50	64152-23	SCREW-SP 1/4-20 X 3/8	1				

COLLECTOR ASSEMBLY

LITTLE WONDER PRO VAC

FIGURE 2

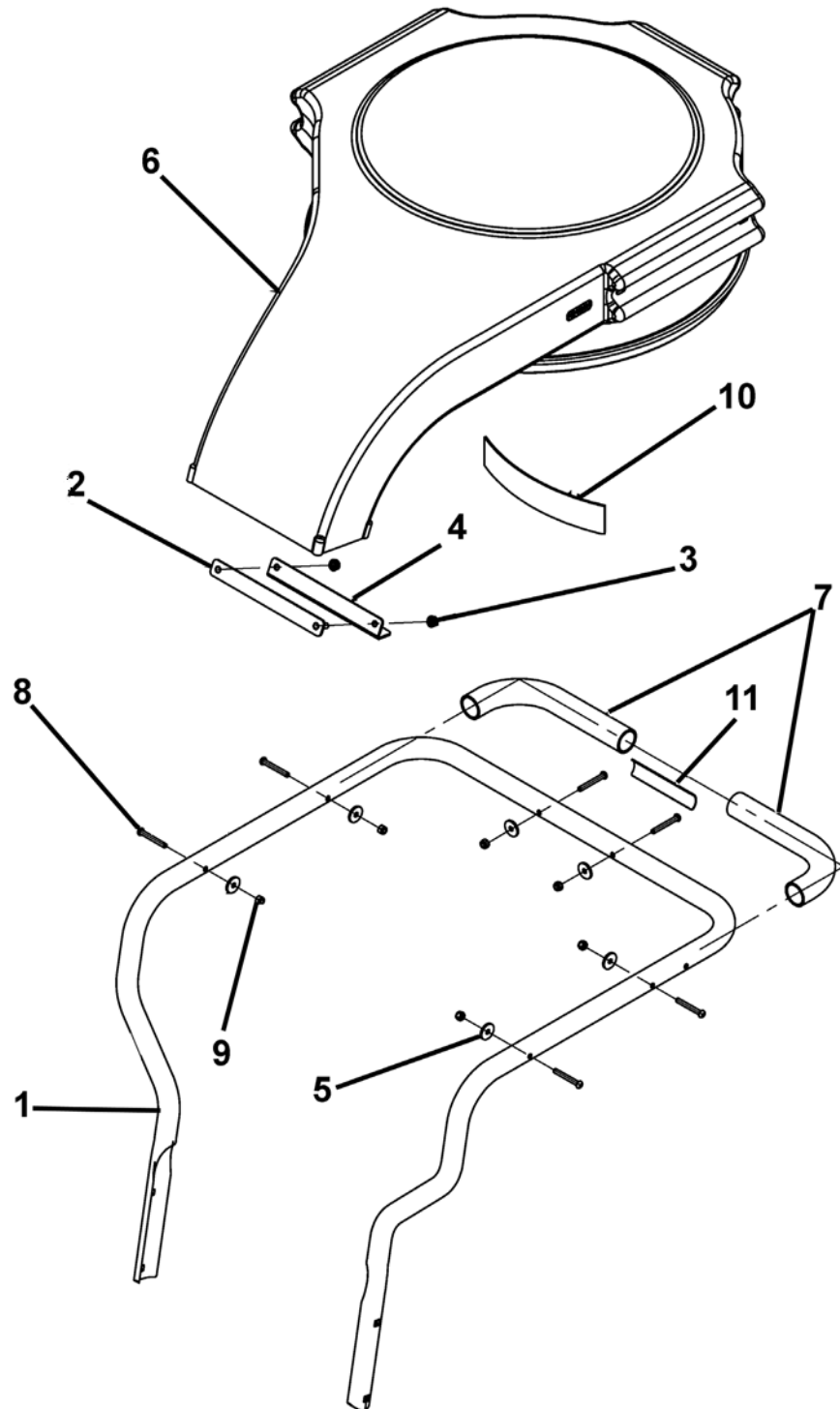

LITTLE WONDER PRO VAC

COLLECTOR ASSEMBLY

FIGURE 2

ITEM	PART NO.	DESCRIPTION	QTY	ITEM	PART NO.	DESCRIPTION	QTY
1	4166406	S-HANDLE	1				
2	600142.7	FLANGE CLAMP PLATE	1				
3	64141-6	NUT-5/16-18	2				
4	600138.7	FLANGE ANGLE COLLECTOR	1				
5	64163-34	WASHER-1/4 COLLECTOR	6				
6	600101	DISCHARGE COLLECTOR	1				
7	600153	GRIP	2				
8	600509	BOLT-BUTTON 1/4-20 X 2	6				
9	644229-01	LOCKNUT-1/4-20	6				
10	600161	HOOK STRIP	1				
11	4166391	LABEL-VAC BAG WARN	1				

LINER ASSEMBLY

LITTLE WONDER PRO VAC

FIGURE 3

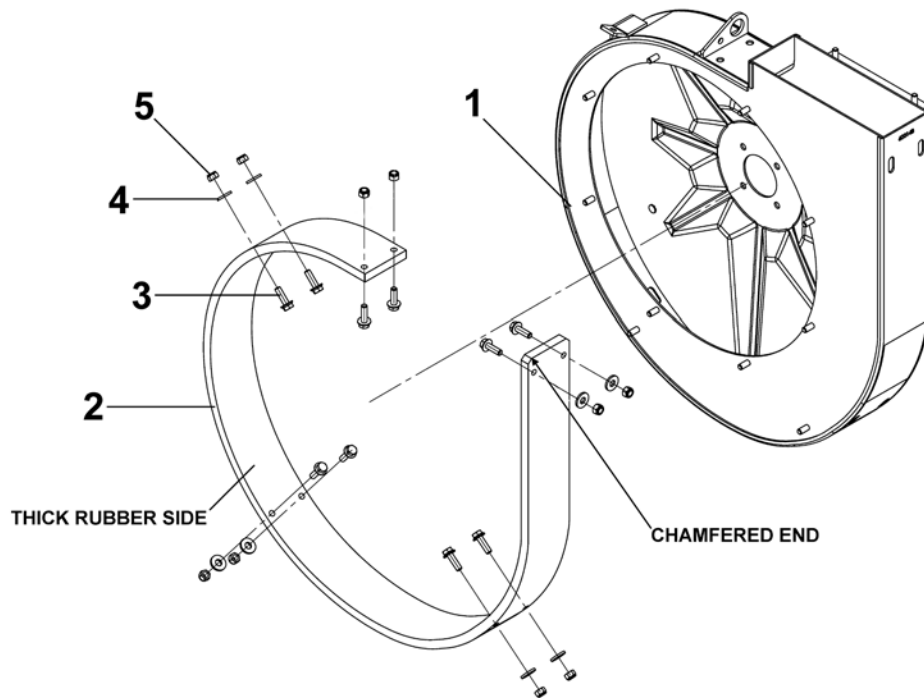

LITTLE WONDER PRO VAC

LINER ASSEMBLY

FIGURE 3

ITEM	PART NO.	DESCRIPTION	QTY	ITEM	PART NO.	DESCRIPTION	QTY
1	4171303	S-HOUSING ASSY	1				
2	600175	LINER	1				
3	720592	BOLT-5/16-18 X 1	10				
4	64163-29	WASHER-25/64 X 1 X 12GA	8				
5	64229-02	LOCKNUT-5/16-18	10				

NOZZLE ASSEMBLY

LITTLE WONDER PRO VAC

FIGURE 4

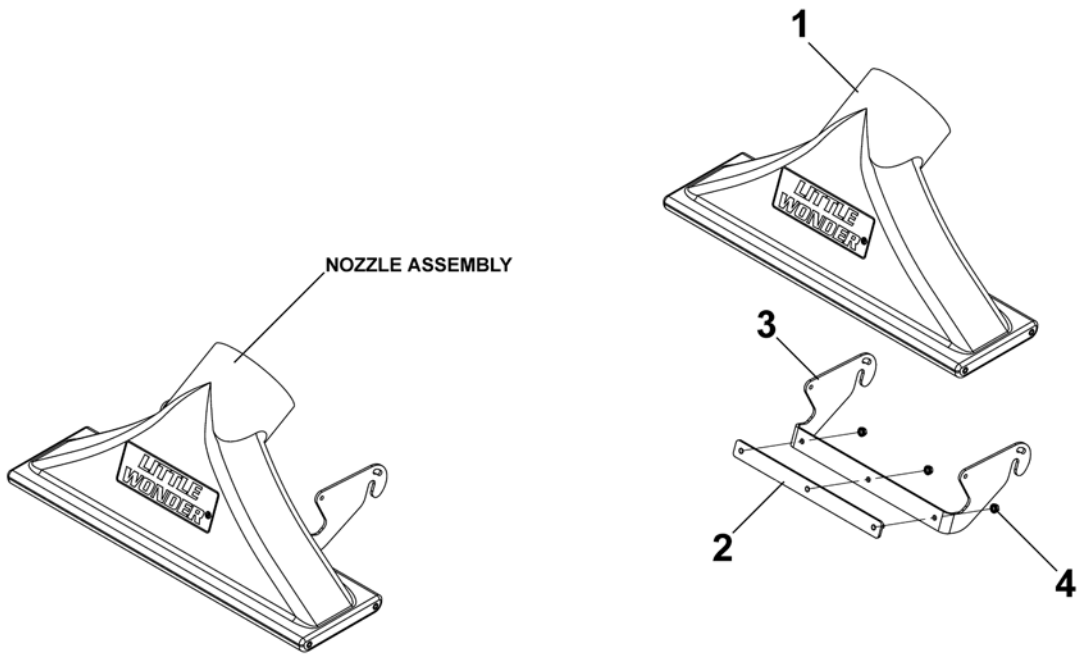

LITTLE WONDER PRO VAC

NOZZLE ASSEMBLY

FIGURE 4

ITEM	PART NO.	DESCRIPTION	QTY	ITEM	PART NO.	DESCRIPTION	QTY
1	600100	NOZZLE	1				
2	600133.7	ASSY-NOZZLE CLMP PLATE 1	1				
3	600183.17	BRKT-NOZZLE VER. 2"	1				
4	64141-6	NUT-FL 5/16-18	3				



**2 YEAR LIMITED SERVICE AND
WARRANTY POLICY
FOR LITTLE WONDER PRO VAC AND PRO VAC SP**

All Little Wonder Pro Vacuums are warranted against defects in material and workmanship for a period of two (2) years from the date of purchase, under the following terms and conditions.

LITTLE WONDER will repair or replace, at its option, any part or parts of the product found to be defective in material or workmanship during the warranty period. Warranty repairs and replacements will be made without charge for parts or labor. All parts replaced under warranty will be considered as part of the original product, and any warranty on the replaced parts will expire coincident with the original product warranty. If you think your LITTLE WONDER Pro Vacuum is defective in material or workmanship, you must return it to a registered dealer with a valid sales receipt or to our factory at 1028 Street Rd., Southampton, PA 18966. Transportation charges to ship your product to us or a registered dealer must be borne by you.

Engines for all gasoline powered products are warranted separately by the engine manufacturer. Therefore, there are no warranties made, expressed or implied, for engines for gasoline powered products by LITTLE WONDER.

LITTLE WONDER assumes no responsibility in the event that the product was not assembled or used in compliance with any assembly, care, safety or operating instructions contained in the Operator's Manual or information accompanying the product. This limited warranty does not cover damages or defects due to normal wear and tear, lack of reasonable and proper maintenance, failure to follow operating instructions or Operator's Manual, misuse, lack of proper storage or accidents, nor does it cover routine maintenance parts and service. This limited warranty does not cover any defects due to repairs or alterations made to the product made by anyone other than LITTLE WONDER or its registered dealers.

You must maintain your LITTLE WONDER Pro Vac by following the maintenance procedures described in the operator's manual. Such routine maintenance, whether performed by you or a registered dealer, is at your expense.

LITTLE WONDER MAKES NO EXPRESS OR IMPLIED WARRANTIES REPRESENTATIONS OR PROMISES EXCEPT THOSE CONTAINED HEREIN. THERE ARE NO OTHER WARRANTIES, INCLUDING WARRANTIES OF MERCHANTABILITY AND FITNESS FOR A PARTICULAR PURPOSE. ALL WARRANTIES OTHER THAN THE EXPRESS WARRANTY SET FORTH ABOVE ARE SPECIFICALLY DISCLAIMED. THE DURATION OF ANY IMPLIED WARRANTY, INCLUDING MERCHANTABILITY AND FITNESS FOR A PARTICULAR PURPOSE, IS LIMITED TO THE DURATION OF THIS WRITTEN LIMITED WARRANTY. LITTLE WONDER DISCLAIMS ALL LIABILITY FOR INDIRECT, INCIDENTAL AND/OR CONSEQUENTIAL DAMAGES IN CONNECTION WITH THE USE OF THE LITTLE WONDER PRO VACUUM PRODUCTS COVERED BY THIS WARRANTY. SOME STATES DO NOT ALLOW LIMITATIONS ON HOW LONG AN IMPLIED WARRANTY LASTS AND/OR DO NOT ALLOW THE EXCLUSION OR LIMITATION OF INCIDENTAL OR CONSEQUENTIAL DAMAGES, SO THAT ABOVE LIMITATIONS AND EXCLUSIONS MAY NOT APPLY TO YOU. THIS WARRANTY GIVES YOU SPECIFIC LEGAL RIGHTS, AND YOU MAY ALSO HAVE OTHER RIGHTS WHICH VARY FROM STATE TO STATE.

LITTLE WONDER
SCHILLER GROUNDS CARE, INC.
1028 STREET ROAD, P.O. BOX 38
SOUTHAMPTON, PA 18966
PHONE: 877-596-6337 • FAX: 215-357-8045
877 - LWONDER
www.littlewonder.com