

LITTLE WONDER®

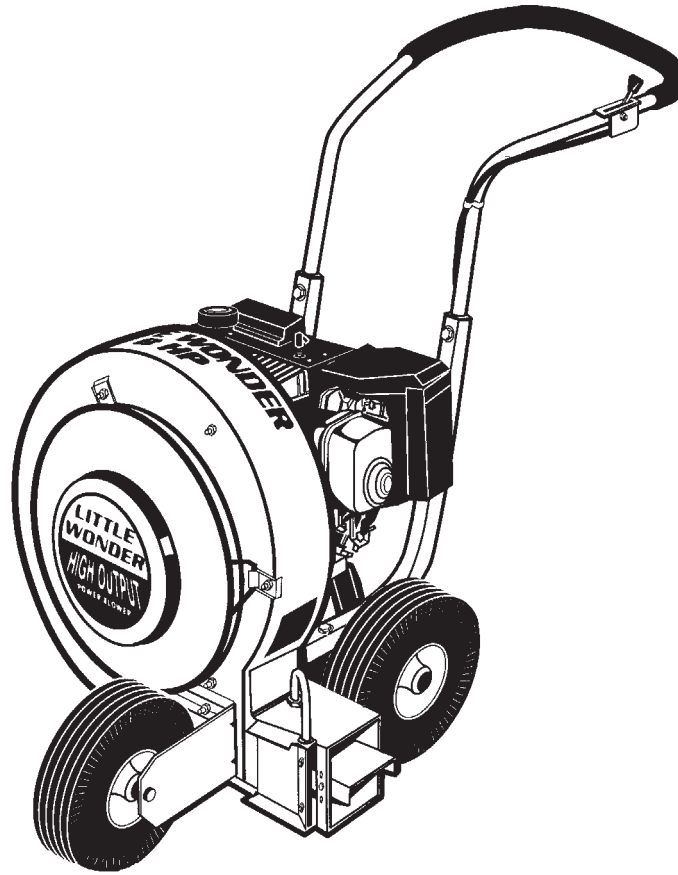

Owners Manual and Safety Instructions
for
HIGH OUTPUT BLOWERS

MANUEL DU PROPRIÉTAIRE ET CONSIGNES DE SÉCURITÉ
pour
SOUFFLANTES À GRAND DÉBIT

MANUAL DEL PROPIETARIO E INSTRUCCIONES
DE SEGURIDAD
para
SOPLADORES DE ALTA POTENCIA

TABLE OF CONTENTS

	Page
I. IMPORTANT INFORMATION	
A. Introduction	2
B. Service Information	3
C. Special Safety Information	3
II. SAFETY AND WARNINGS	
A. Safety Decals (Labels)	4
B. General Safety Rules	5
C. Warnings - Don'ts	5
D. Warnings - Do's	6
E. Engine/Fuel Warnings Don'ts	6
F. Engine/Fuel Warnings Do's	7
III. ASSEMBLY INSTRUCTIONS	7
IV. OPERATING INSTRUCTIONS	8
V. MAINTENANCE	8
VI. PARTS EXPLOSIONS	9 - 11
VII. WARRANTY POLICY	12

MANY USES :

The extreme versatility offered by **Little Wonder's** line of blowers makes them ideally suited for a wide variety of jobs - blowing leaves, grass clippings, and thatch, blowing tennis courts dry, cleaning large driveways, stadiums, parking lots and other hard surfaces, precleaning roofs before repair and countless other jobs.

I. INPORTANT INFORMATION

A. INTRODUCTION

On behalf of everyone at **Little Wonder**, we would like to thank you for your purchase of a **Little Wonder** Gasoline Powered (Petrol-driven) High Output Blower. this professional blower was designed to the highest standards to ensure you many hours of uninterrupted service.

This manual provides the information necessary for safe and efficient operation and service. For your safety, it is critically important that you read and understand this entire manual before operating your blower.

 **Warning:** The Engine Exhaust from this product contains chemicals known to the State of California to cause cancer, birth defects or other reproductive harm.

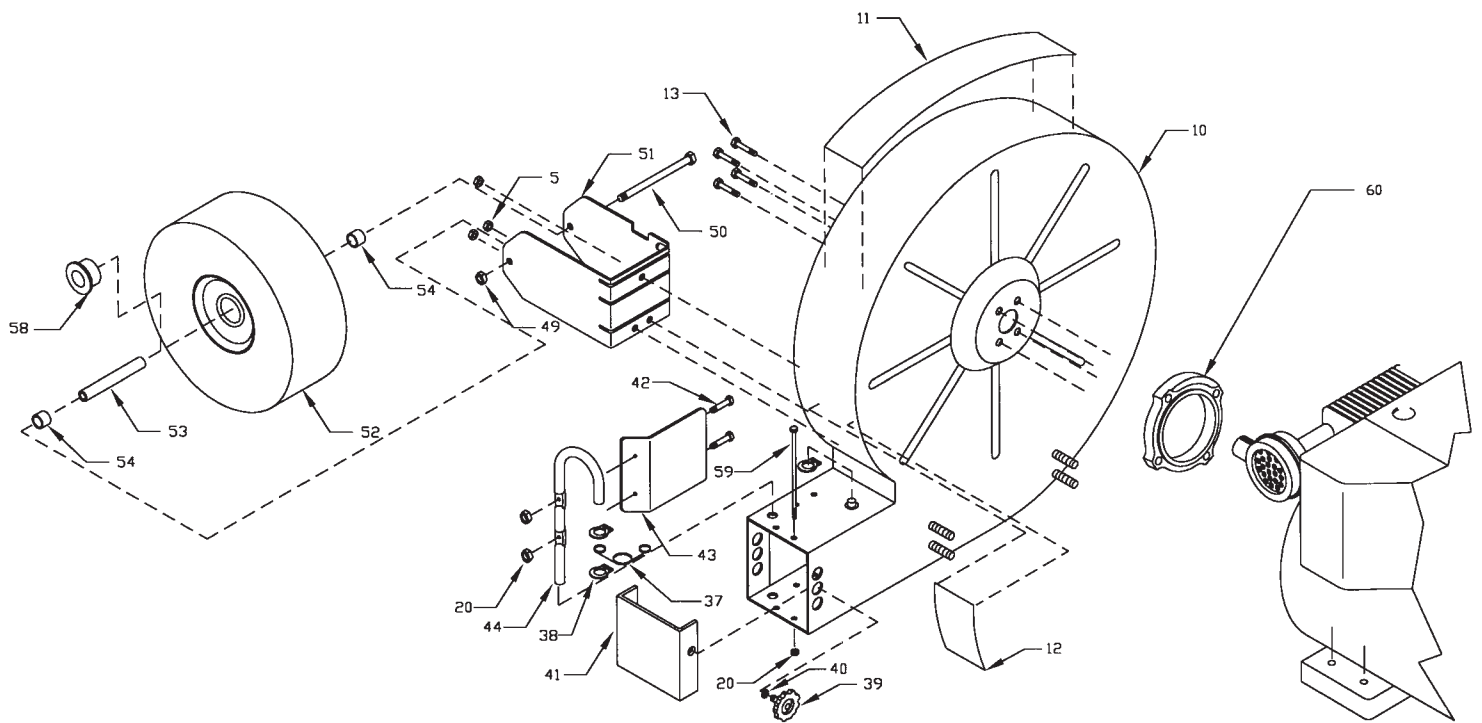

Key #	Part #	Description	Quantity Per Model Number				
			9600	9810	9900	9100	9130
5	114B	5/16-18 Serrated Flanged Lock Nut	14	14	14	14	14
10	910000	6 HP Housing	1	-	-	-	-
10	910020	8, 9 HP Housing	-	1	1	-	-
10	910040	10, 13 HP Housing	-	-	-	1	1
11	910629	Little Wonder Housing Label - 6 HP	1	-	-	-	-
11	910612	Little Wonder Housing Label - 8 HP	-	1	-	-	-
11	910613	Little Wonder Housing Label - 9 HP	-	-	1	-	-
11	910628	Little Wonder Housing Label - 10 HP	-	-	-	1	-
11	910625	Little Wonder Housing Label - 13 HP	-	-	-	-	1
12	910609	Warning Label	1	1	1	1	1
13	910503	5/16-24 x 3/4 Whiz Head Flange Bolt	4	4	4	4	-
13	910517	5/16-24 x 1 3/8 Bolt grd 5	-	-	-	-	4
20	973	10-32 2-Way Lock Nut	6	6	6	7	7
37	910130	Deflector Spring	1	1	1	1	1
38	8-18	Retaining Ring	3	3	3	3	3
39	910131	Knob	1	1	1	1	1
40	963	5/16 External Tooth Lock Washer	1	1	1	1	1
41	910100	6 HP Side Deflector	1	-	-	-	-
41	910110	8, 9 HP Side Deflector	-	1	1	-	-
41	910120	10, 13 HP Side Deflector	-	-	-	1	1
42	329	10-32 x 5/8 Serrated Flange Screw	2	2	2	2	2
43	910105	6 HP Internal Deflector	1	-	-	-	-
43	910112	8, 9 HP Internal Deflector	-	1	1	-	-
43	910122	10, 13 HP Internal Deflector	-	-	-	1	1
44	910132	Deflector Handle	1	1	1	1	1
49	102B	3/8-16 2-Way Lock Nut	1	1	1	1	1
50	900501	3/8-16 x 5 1/4 Bolt	1	1	1	1	1
51	910402	Pneumatic Front Wheel Bracket	1	1	1	1	1
52	934	Pneumatic Wheel Symetrical	1	1	1	1	1
53	900404	Pneumatic Wheel Sleeve	1	1	1	1	1
54	900405	Front Wheel Bracket Spacer	2	2	2	2	2
58	934B	Pneumatic Wheel Bearing	6	6	6	6	6
59	300507	10-32 x 5 1/2 Hex M/S	4	4	4	5	5
60	910134	Engine Housing Spacer - 13 HP	-	-	-	-	1

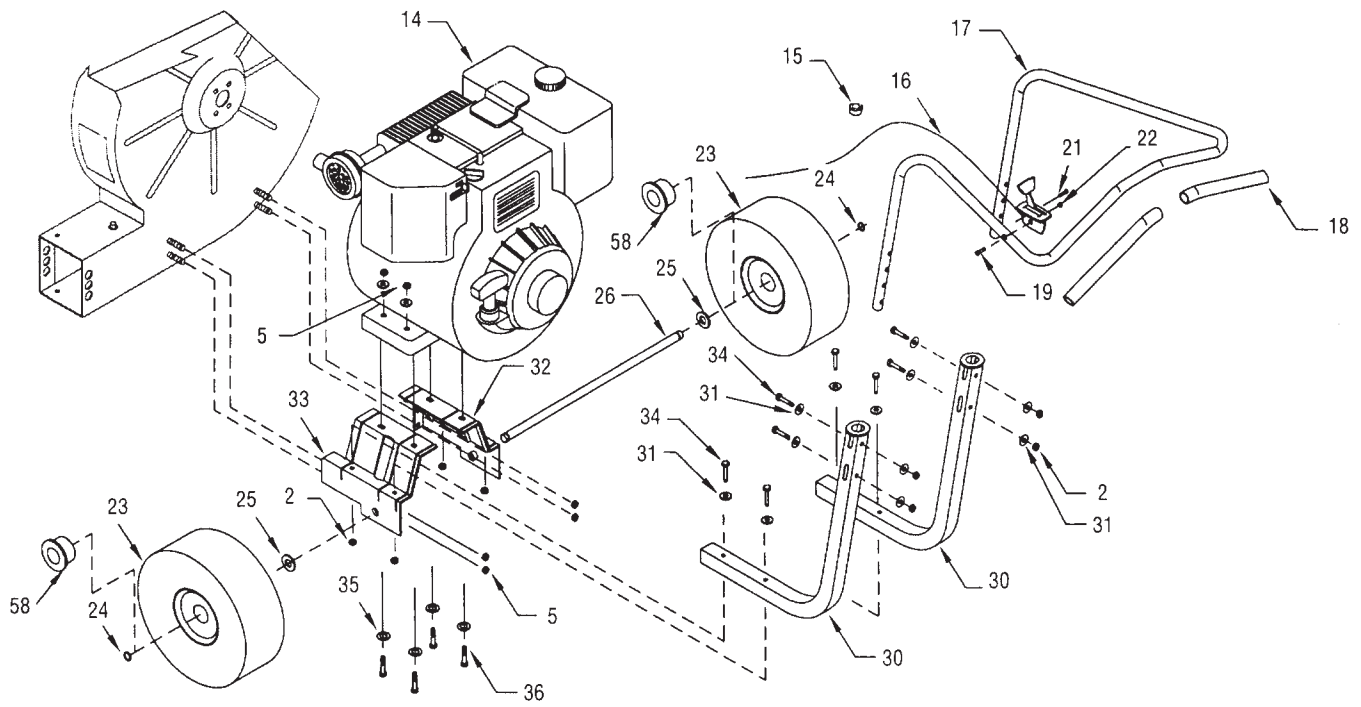

Key #	Part #	Description	Quantity Per Model Number				
			9600	9810	9900	9100	9130
2	114C	5/16-18 Nylon Insert Nut	11	11	11	11	11
5	114B	5/16-18 Serrated Flanged Lock Nut	14	14	14	14	14
14	910914	6 HP Intek Engine	1	-	-	-	-
14	910915	8 HP IC Intek Engine	-	1	-	-	-
14	930	9 HP Honda Engine	-	-	1	--	-
14	910913	10 HP IC Intek Engine	-	-	-	1	-
14	910912	13 HP Honda Engine	-	-	-	-	1
15	946	Throttle Clip	1	1	1	1	1
16	910301	Throttle Cable	1	1	1	1	1
17	900301	Upper Handle	1	1	1	1	1
18	900302	Grip (set of 2)	1	1	1	1	1
19	378	1/4-20 x 1 1/2 HHCS gr5	1	1	1	1	1
21	910526	10-32 x 3/4 Self tapping Sheet Metal Screw	1	1	1	1	1
22	972	1/4-20 2-Way Lock Nut	1	1	1	1	1
23	934-1	Pneumatic Wheel Offset	2	2	2	2	2
24	312	Retaining Ring	2	2	2	2	2
25	405-1	5/8 SAE Flat Washer	2	2	2	2	2
26	932-1	Axle	1	1	1	1	1
30	916-2	Lower Handle	2	2	2	2	2
31	163	5/16 Flat Washer	12	12	14	12	12
32	910009	6/8/10 HP Right Blower Deck	1	1	-	1	-
32	910030	9 HP Right Deck	-	-	1	-	-
32	910069	13 HP Right Deck	-	-	-	-	1
33	910007	6/8/10 HP Left Blower Deck	1	1	-	1	-
33	910028	9 HP Left Deck	-	-	1	-	-
33	910067	13 HP Left Deck	-	-	-	-	1
34	942	5/16-18 x 1.75 HHCS gr5	8	8	8	8	8
35	129D	5/16 Regular Split Lock Washer	4	4	4	4	4
36	942	5/16-18 x 1.75 HHCS gr5	-	4	4	4	4
36	113	5/16-18 x 1.5 HHCS	4	-	-	-	-
58	934B	Pneumatic Wheel Bearing	6	6	6	6	6

B. SERVICE INFORMATION

ENGINE

- Refer to the enclosed Engine Manual provided by the engine manufacturer.
- Or an authorized repair service of the manufacturer.

OTHER COMPONENTS

- Contact your local Little Wonder dealer.

C. SPECIAL SAFETY INFORMATION

▲ WARNING DANGER ▲
ATTENTION; THIS SYMBOL POINTS OUT OUR MOST IMPORTANT SAFETY INSTRUCTIONS.

WHEN YOU SEE THIS SYMBOL, ▲ HEED ITS' WARNING!! STAY ALERT!!

▲ WARNING DANGER ▲
TO REDUCE THE POTENTIAL FOR ACCIDENTS, COMPLY WITH THE SAFETY INSTRUCTIONS IN THIS MANUAL. FAILURE TO COMPLY MAY RESULT IN SERIOUS PERSONAL INJURY AND/OR EQUIPMENT AND PROPERTY DAMAGE.

II. SAFETY AND WARNINGS

▲ WARNING DANGER ▲
IMPROPER USE OR CARE OF THIS BLOWER, OR FAILURE TO WEAR PROPER PROTECTION CAN RESULT IN SERIOUS INJURY.

READ AND UNDERSTAND THE RULES FOR SAFE OPERATION AND ALL INSTRUCTIONS IN THIS MANUAL.

WEAR HEARING AND EYE PROTECTION.

⚠ A. SAFETY DECALS (LABELS)

An important part of the safety system incorporated in this blower are the warnings and informational decals (labels) found on various parts of the blower. These decals (labels) must be replaced if they become illegible due to abrasion, etc. It is your responsibility to replace the decals (labels) when they become hard to read. The location of these decals (labels) and their part numbers for ordering are shown below.

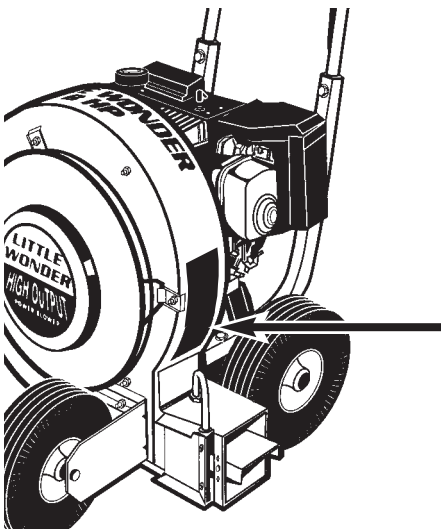
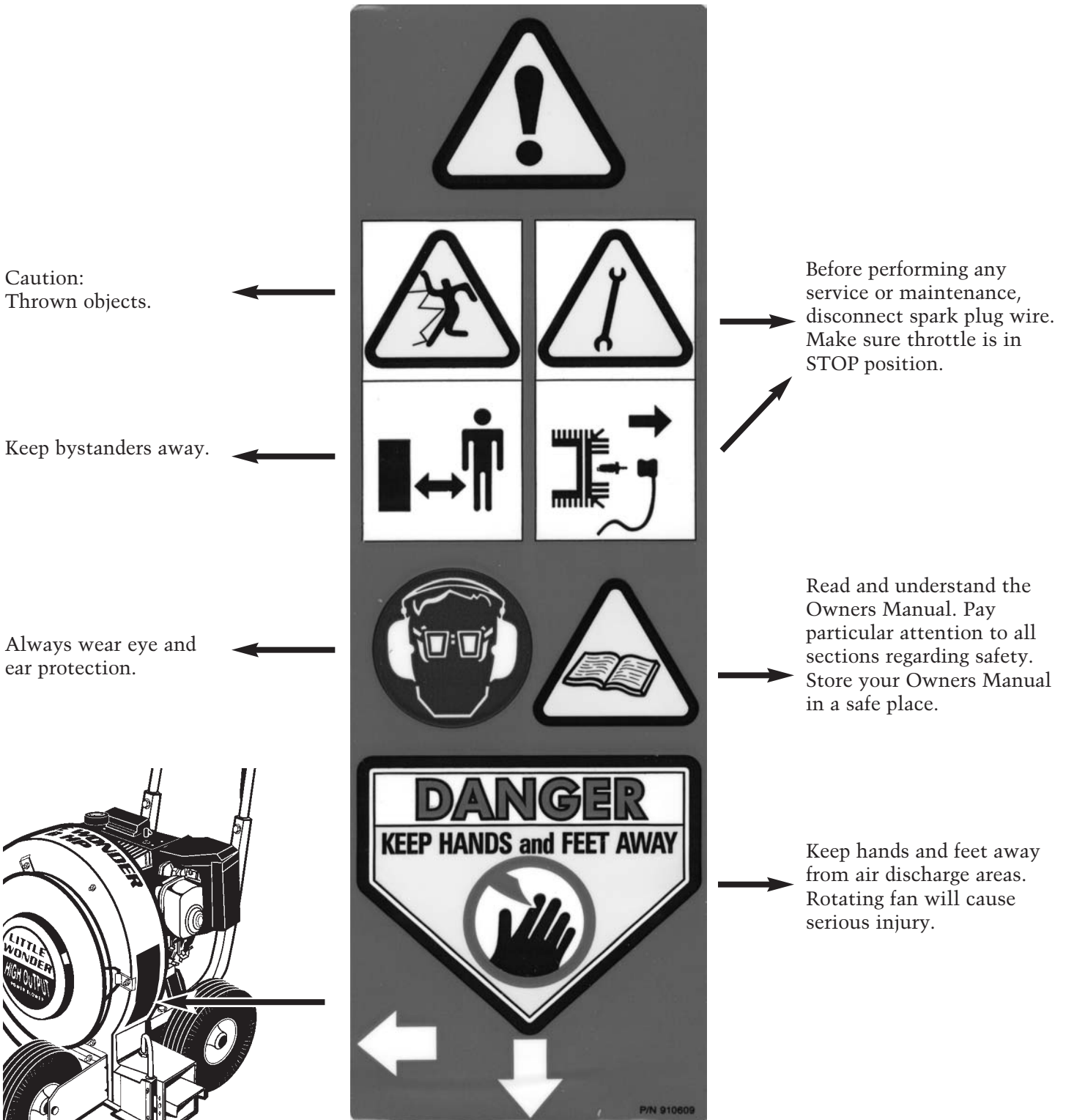

Location of label on blower

P/N 910609
Warning Label

BLOWER BOLT/NUT TORQUE SPECIFICATIONS

Location	Bolt / nut size	P/N	Min. torque Ft-Lbs (in-lbs)	Max. Torque Ft-Lbs (in-lbs)
Housing to engine face	5/16-24 x 3/4 flange head	910503	22 (264)	28 (336)
Deck to housing	5/16-18 flange nut	114-B	16 (192)	22 (276)
Engine to deck	5/16-18 x 1.5/1.75 gr 5	113/942	19 (228)	25 (300)
Lower handle to deck	5/16-18 x 1.75 gr 5	942	19 (228)	25 (300)
Upper handle to lower handle	5/16-18 x 1.75 gr 5	942	19 (228)	25 (300)
Throttle to handle	1/4-20 X 1.5 gr 2	378	4 (48)	6 (72)
Interior deflector to hook	10-32 x .625 flange head gr 5	329	(52)	(71)
Fan to crankshaft (9900)	7/16-20 x 1.5 flange head gr 5	910508	61	81
Fan to crankshaft (9100, 9130, 9600, 9810)	3/8-24 x 1.5 flange head gr 5	910518	39	51
Front panel to housing (short stud)	5/16-18 flange nut	114-B	16 (192)	22 (276)
Intake guard clamp (long stud)	5/16-18 muloc nut	114-C	—	8 (100)
Wheel bracket to housing	5/16-18 flange nut	114-B	16 (192)	22 (276)
Front wheel axle bolt	3/8-16 x 5.25 gr 5	900501	34	45

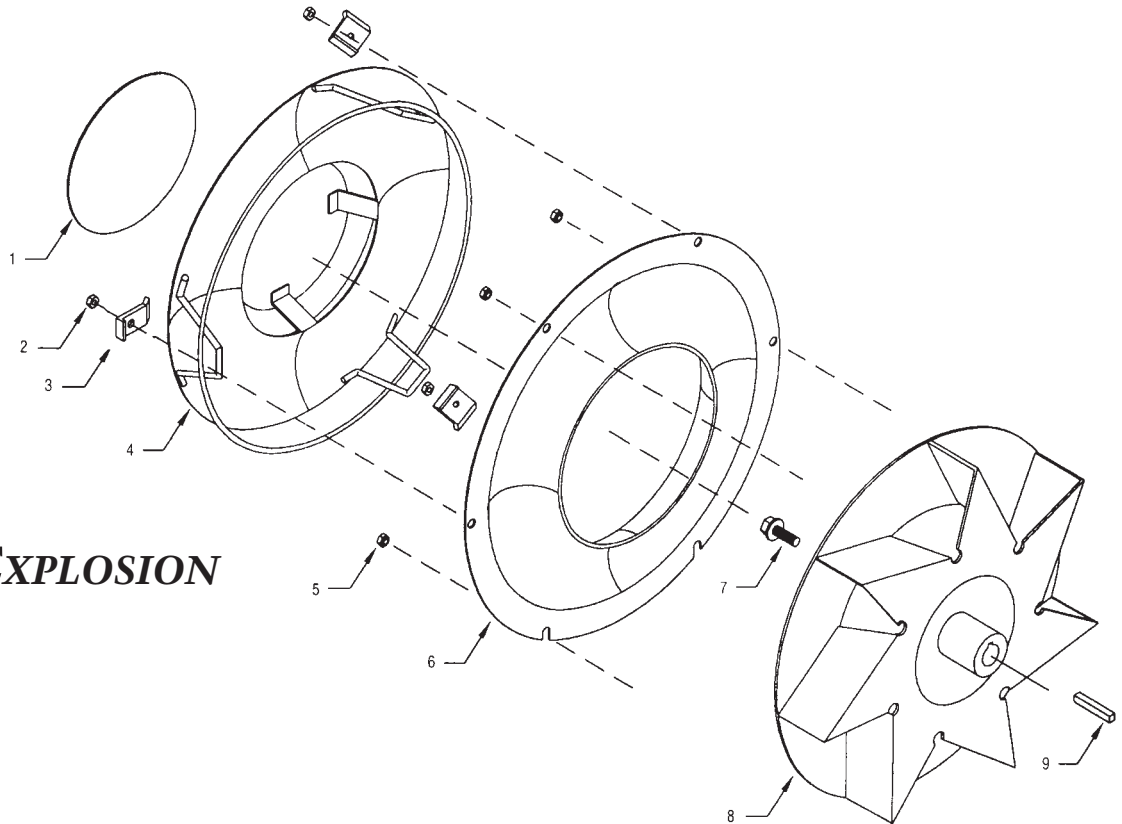

V1. PARTS EXPLOSION

Key #	Part #	Description	Quantity Per Model Number				
			9600	9810	9900	9100	9130
1	910610	Intake Guard Label	1	1	1	1	1
2	114C	5/16-18 Nylon Insert Nut	11	11	11	11	11
3	911130	Intake Guard Clamp	3	3	3	3	3
4	911100	Intake Guard Assy	1	1	1	1	1
5	114B	5/16-18 Serrated Flanged Lock Nut	14	14	14	14	14
6	911120	Front Panel	1	1	1	1	1
7	910508	7/16-20 x 1 1/2 Serrated Flange Bolt gd 5	-	-	1	-	-
7	910518	3/8-24 x 1 1/2 Serrated Flange Bolt gd 5	1	1	-	1	1
8	910200	6 HP Fan	1	-	-	-	-
8	910210	8 HP Fan	-	1	-	-	-
8	910220	9 HP Fan	-	-	1	-	-
8	910230	10 HP, 13 HP Fan	-	-	-	1	1
9	915	Key 1/4 x 1/4 x 2	1	1	1	1	1

WARNING - ALL LITTLE WONDER BLOWERS ARE SHIPPED WITHOUT OIL. WHEN FILLING OIL - Use SAE 30 Oil. REFER TO ENGINE MANUFACTURES INSTRUCTION MANUAL FOR PROPER ENGINE OPERATION INSTRUCTIONS

IV. OPERATING INSTRUCTIONS

Refer to Engine Manual for Engine Operation.

Little Wonder recommends using SAE 30 Oil. The use of multi-viscosity oil will result in high oil consumption and possible engine damage.

Leaves, thatch or other debris can be directed into windrows or piles, by simply maneuvering the unit and directing the flow of air accordingly.

Air flow can be directed to the side or front by the two-position deflector. The front discharge position is used to remove debris from along walls, fences, etc. the side discharge position is used to form windrows or piles.

The horizontal deflector directs air downward to "chisel" under wet, heavy leaves and litter. The velocity is regulated by the throttle control.

Moving the deflector to the upper hole allows for a greater volume of air to be directed downward. Moving the deflector to the lower hole allows for a greater volume of air to be directed upward. To reduce windrowing or to blow over obstacle, point deflector upward.

Slight changes in deflector will have a big effect on air flow. Experiment until you find the best position for your needs.

For best performance, be sure engine recoil starter assembly, the blower intake and outlet areas are clear and free of leaves or other debris.

V. MAINTENANCE INSTRUCTIONS

1. Keep all nuts, bolts, and screws tight.
2. Never store the Blower with fuel in its fuel tank inside a building or in a confined space where fumes may reach an open flame or sparks.
3. Always refer to the instruction manual for important details if the product is to be stored for an extended period.
4. Engine - 4 cycle. (Refer to engine manufacturer's operating instructions for fuel recommendations and additional information.)
5. Tires - Tubeless. Inflate to air pressure of 30 P.S.I.
6. Labels should be inspected before each use. Replace damaged labels immediately.

To prevent accidental starting, remove spark plug wire when servicing engine or equipment.

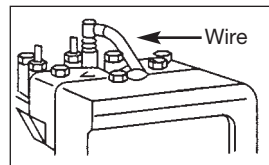

Check oil level regularly. Be sure correct oil level is maintained. Check oil level after every 5 hours of operation, or daily, before starting engine. **Use SAE 30 Oil.** Change oil after first 5 hours of operation. Remove drain plug and drain oil while engine is warm. Replace drain plug. Remove oil fill plug and refill with new oil. Start and run engine at idle for 30 seconds. Stop engine. Wait 30 seconds and re-check oil level. If required, add oil to overflowing at oil fill plug.

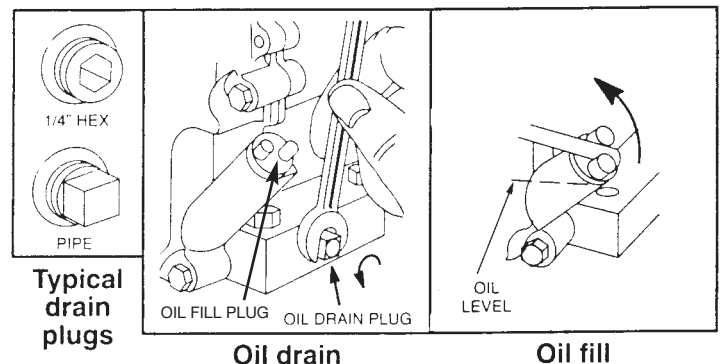

DIRECTIONS FOR FAN REMOVAL:

(This procedure must be done by qualified **Little Wonder** dealer)

1. Remove intake guard and front panel.
2. Remove bolt securing fan to engine crankshaft.
3. The fan has a 3/4-16 nut welded on the fan hub. Insert a 3/4-16 grade 5 bolt (or better) and jack or push the fan off the engine. (**Little Wonder** part #910515 pressure screw is recommended.) In some instances, it may be necessary to apply heat in area of fan hub as Loctite 242 has been used to secure the fan to the engine crank shaft. Be careful not to overheat.
4. Use a new bolt (P/N 910508 or P/N 910518) and Loctite 242 to insure a secure fit upon re-assembling.

⚠ B. GENERAL SAFETY RULES

1. Read and understand the owner's manual. Pay particular attention to all sections regarding safety. Store your owners manual in a safe place.
2. **⚠ WARNING - KEEP CHILDREN, PETS, and BYSTANDERS AWAY** - Do not permit children to contact blower. Keep children a safe distance from work area. Never allow a person mentally ill, under influence of alcoholic drinks or drugs or too young in age, to operate the blower.
3. **DON'T OVERREACH OR STAND ON UNSTABLE SUPPORT.** - Keep good footing and balance at all times.
4. **MULTIPLE OPERATORS** - Keep a safe distance between two or more operators when working together simultaneously.
5. **WARNING** - Fan coasts after turn off.

⚠ WARNING DANGER ⚠
**IF BLOWER IS USED IMPROPERLY
OR SAFETY PRECAUTIONS ARE NOT
FOLLOWED, THE USER RISKS SERIOUS
INJURY TO THEMSELVES AND OTHERS.**

**READ AND UNDERSTAND THE
FOLLOWING BEFORE ATTEMPTING TO
OPERATE THIS BLOWER.**

⚠ C. WARNINGS - DONT'S

1. **⚠ DANGER ROTATING FAN - KEEP HANDS AWAY. DON'T attempt to remove materials from intake or discharge when blower is running.**
2. **⚠ DANGER - DO NOT INSTALL OR REMOVE ATTACHMENTS WHILE BLOWER IS RUNNING. Turn off engine to make changeover. Be sure throttle is in the stop position, and the blower has come to a complete stop. Remove the spark plug wire before removing material.**
3. **DO NOT POINT THE BLOWER OUTLET** in the direction of people, cars, glass, or other similar items which could be injured or damaged by blown debris.
4. **DO NOT ATTEMPT TO REPAIR BLOWER** - Have repairs made by qualified **Little Wonder** dealer or repairman. See that only **Little Wonder** and recommended engine manufacturers replacement parts are used.

A *D. WARNINGS — Do's*

1. **DRESS PROPERLY** — Do not wear loose clothing or jewelry (jewellery) . They can be caught in moving parts. Use of sturdy gloves, non-skid footwear and safety glasses are recommended. Always wear ear protectors where possible. Use face filter to avoid breathing dust.
2. **STAY ALERT** — Watch what you are doing and use common sense. Do not operate blower when fatigued.
3. **KEEP HANDS AWAY FROM AIR INTAKE AND AIR OUTLET CHUTE** — Keep both hands on handles when power is on.
4. **MAINTAIN AND EXAMINE BLOWER WITH CARE** — Follow maintenance instructions given in manual. Do not use the blower if the muffler is defective or missing.
5. **STORE BLOWER INDOORS** — When not in use, store blower indoors in a sheltered area (a dry place) where it's not accessible to children. The blower, as well as fuel, should not be stored in a house. Keep throttle in the stop position.
6. **BE SURE BLOWER IS FULLY ASSEMBLED** — Never operate blower without all guards and deflectors in place. Ensure that all nuts, bolts, screws are installed and properly tightened.
7. **ALWAYS KEEP THE THROTTLE IN THE "STOP" POSITION WHEN NOT IN USE.**
Always keep a safe distance between two or more operators when working together simultaneously.
8. **WARNING! IN ORDER TO AVOID ENGINE DAMAGE DUE TO OVER-HEATING OR OVER-REVVING, KEEP ENGINE RECOIL STARTER ASSEMBLY, THE BLOWER INTAKE AND OUTLET AREAS, OR HOSE ACCESSORIES CLEAR AND FREE OF LEAVES OR OTHER DEBRIS.**

A *E. ENGINE/FUEL WARNINGS - DONT'S*

A **WARNING DANGER** **A**
HANDLE FUEL WITH CARE, IT IS HIGHLY FLAMMABLE. FUELING (FUELLING) A HOT ENGINE OR NEAR AN IGNITION SOURCE CAN CAUSE FIRE AND RESULT IN SERIOUS PERSONAL INJURY AND/OR PROPERTY DAMAGE.

1. **Do not** smoke while handling fuel.
2. **Do not** refuel a hot or running engine.
3. **Do not** fill tank indoors.
4. **CAUTION** — Do not start or run engine indoors as poisonous carbon monoxide is emitted.
5. **Do not** operate in un-ventilated area.
6. **Do not** use the blower when electric system causes spark outside the cylinder. Check spark plug from time to time. When checking, keep plug a safe distance from cylinder to avoid burning of evaporated fuel from cylinder.

F. ENGINE/FUEL WARNINGS - DO'S

HANDLE GASOLINE (PETROL) WITH CARE. IT IS HIGHLY FLAMMABLE.
Refuel before starting work.

Always use fresh gasoline (petrol). Stale gasoline (petrol) can cause leakage.

Always pull starter cord slowly until resistance is felt. Then pull cord rapidly to avoid kick-back and prevent arm or hand injury.

Always operate engine with spark arrestor installed and operating properly. The use of spark arrestor mufflers is required by law in the state of California (Section 4442 of the California Public Resources Code), as well as in other states or municipalities. Federal laws apply on federal lands.

Replace gasoline (petrol) cap securely. If fuel is spilled move blower and fuel container from area and do not create a source of ignition.

Avoid spilling fuel or oil. Always wipe unit dry before using. Move at least 10 feet away from the fueling (fuelling) point before starting engine.

Always store gasoline (petrol) in an approved container. Fill tank outdoors with extreme care.

III. BLOWER ASSEMBLY INSTRUCTIONS.

***NOTE : Numbers in brackets (#) represent Key Numbers shown on Parts List, and parts explosion. See pages 9-11.**

- A. Install lower handles (30) on top of deck (32, 33). Secure with four cap screws 5/16-18 x 1 3/4 (34), four 5/16 flat silver washers (31), and four 5/16-18 nylon nuts (2), finger tight.
- B. Install upper handle (17) with four cap screws 5/16-18 x 1 3/4 (34), eight 5/16 washers (31), and four 5/16-18 nylon nuts (2), finger tight. Tighten lower handle nuts and bolts. Tighten upper handle nuts and bolts until the lower handle tubing pinches the upper handle. It will be normal for the lower handle tubing to crush slightly.
- C. Attach throttle cable to upper handle with 1/4-20 x 1 1/2" cap screw (19) and 1/4-20 lock nut (22) through hole on upper handle (17). For Briggs and Stratton INTEK series engines, the throttle control will mount on the right hand side. For Honda engines, it will mount on the left. Insert the 10-32 x 3/4" self-tapping screw through the hole of the throttle control and into the pilot hole in the handle and tighten. (NOTE: Over tightening the screw on the left hand mounted controls could cause damage to the control.) Once the 10-32 screw is tightened, go back to the 1/4-20 screw and tighten it enough to get a smooth action in the control. If the throttle does not maintain it's setting once you start the engine, tighten this screw some more. Connect throttle clip (15) to upper handle.
- D. Tilt blower back on handle and install front wheel bracket (51) over the three studs on lower front of blower housing. Secure with three 5/16-18 flange nuts (5).
- E. Insert pneumatic wheel sleeve (53) in front pneumatic wheel (52). Install pneumatic wheel spacers (54) over the axle sleeve on both sides of wheel and install in front wheel bracket (51). Insert 3/8-16 x 5 1/4 axle bolt (50) through wheel bracket and axle sleeve. Secure with 3/8-16 axle nut (49).

WARNING - All Little Wonder blowers are shipped WITHOUT OIL. Refer to engine manufactures instruction manual for proper engine operation instructions

5 YEAR LIMITED SERVICE & WARRANTY POLICY
FOR GASOLINE POWERED (PETROL-DRIVEN)
HIGH OUTPUT BLOWERS

All **Little Wonder** Gasoline Powered (Petrol-driven) High Output blowers are guaranteed against defects in material and workmanship for a period of FIVE YEARS from date of purchase, when used for RESIDENTIAL SERVICE, or COMMERCIAL SERVICE. Any **Little Wonder** Gasoline powered (Petrol-driven) High Output Blower or part found to be defective within the warranty period is to be returned to any registered **Little Wonder** dealer.

Engines for all gasoline powered (Petrol-driven) products are warranted separately by the engine manufacture. Therefore, there are no warranties made, expressed or implied, for engines for gasoline powered products by **Little Wonder**.

Transportation charges for parts and units submitted for replacement under this warranty must be borne by the purchaser.

THIS WARRANTY shall not be effective if the product has been subject to misuse, negligence or accident, or if the product has been repaired or altered outside of our Southampton factory or authorized repair facility in any respect which affects its condition or operation.

LITTLE WONDER shall not be liable for any special indirect or consequential damages arising from defective equipment. Any implied warranty, including merchantability of fitness for a particular purpose, shall not extend beyond the written warranty period.

THIS WARRANTY shall only be effective if the enclosed Warranty/Registration card is properly filled out and returned to **Little Wonder**, Div. of Schiller-Pfeiffer, Inc. at time of purchase.

LITTLE WONDER®

DIVISION OF SCHILLER-PFEIFFER, INCORPORATED
1028 STREET ROAD, P.O. BOX 38
SOUTHAMPTON, PA 18966
PHONE 215-357-5110 • FAX 215-357-8045
TOLL FREE : 1-877-LWONDER
5 9 6 6 3 3 7