



Ball Bearing Pulley Upgrade Self-Propelled Lawn Vacuum

Kit P/N: 600300

1. Turn off engine. Remove Spark Plug Wire from Spark Plug. Chock or block wheels of vacuum to prevent it from rolling.
2. Remove Debris Bag from vacuum.
3. Remove 3 hex head bolts that attach Belt Guard to Deck. (Use 7/16" wrench or socket.) Set Belt Guard aside. **Note how V Belt wraps around each of 4 pulleys and how it "twists"**.
4. Remove 4 hex head bolts that attach Recoil Starter Cover to Engine Standoffs. (Use 8 millimeter or 5/16" nut driver, socket or wrench.) Remove Recoil Starter Cover.
5. Loosen (but do not remove) 2 hex head bolts that attach Fixed Idler Bracket to Deck. (Use 7/16" wrench or socket.) This allows clearance for belt to be removed.
6. Press down on Belt Tension Lever and lift V Belt off its pulley. Release Belt Tension Lever. Remove V Belt from Engine Pulley and Transaxle Pulley. Discard used V Belt.
7. Remove 2 hex head bolts that attach Fixed Idler Bracket to Deck. Lift Fixed Idler Bracket from deck.
8. Remove 2 hex head bolts that attach Belt Tension Lever Bracket to Deck. From under Deck, remove Spring from Belt Tension Lever. Lift Belt Tension Lever Bracket from under deck.
9. Remove and discard Pulleys with bearings and the Shoulder Bolts (600526) that hold them on from both the Fixed Idler Bracket and the Belt Tension Lever.
10. Install new Pulley with Ball Bearings (600292) onto Fixed Idler Bracket and the Belt Tension Lever with the new 3/8-16 Hex Head Bolts (600275) and one spacer (600274) on each side of Pulley with Bearing. Torque bolt to 30 foot-pounds. Install 3/8-16 Thin Jam Nut (600541) on opposite side of bracket and tighten to 10 foot-pounds to lock bolt into place. Refer to Illustration.
11. Reverse steps 8 through 1 to finish installation. Install new V Belt with the same "twists" that the old V Belt made around the pulleys. Make sure the "V" side of the V Belt goes into each pulley. Before replacing Belt Guard or starting engine, pull Recoil Starter Handle several times to make sure V Belt rides in the grooves of each pulley.
12. Make sure Belt Tension Lever and return spring operate smoothly. If it sticks or does not operate smoothly, lubricate the Belt Tension Lever and its mounting bracket with a few drops of Motor Oil, or other medium weight oil. Push Belt Tension Lever down and release it several times to allow lubrication to penetrate between lever and mounting bracket. Proper operation of the Belt Tension Lever and its return spring will maximize the life of your V Belt.



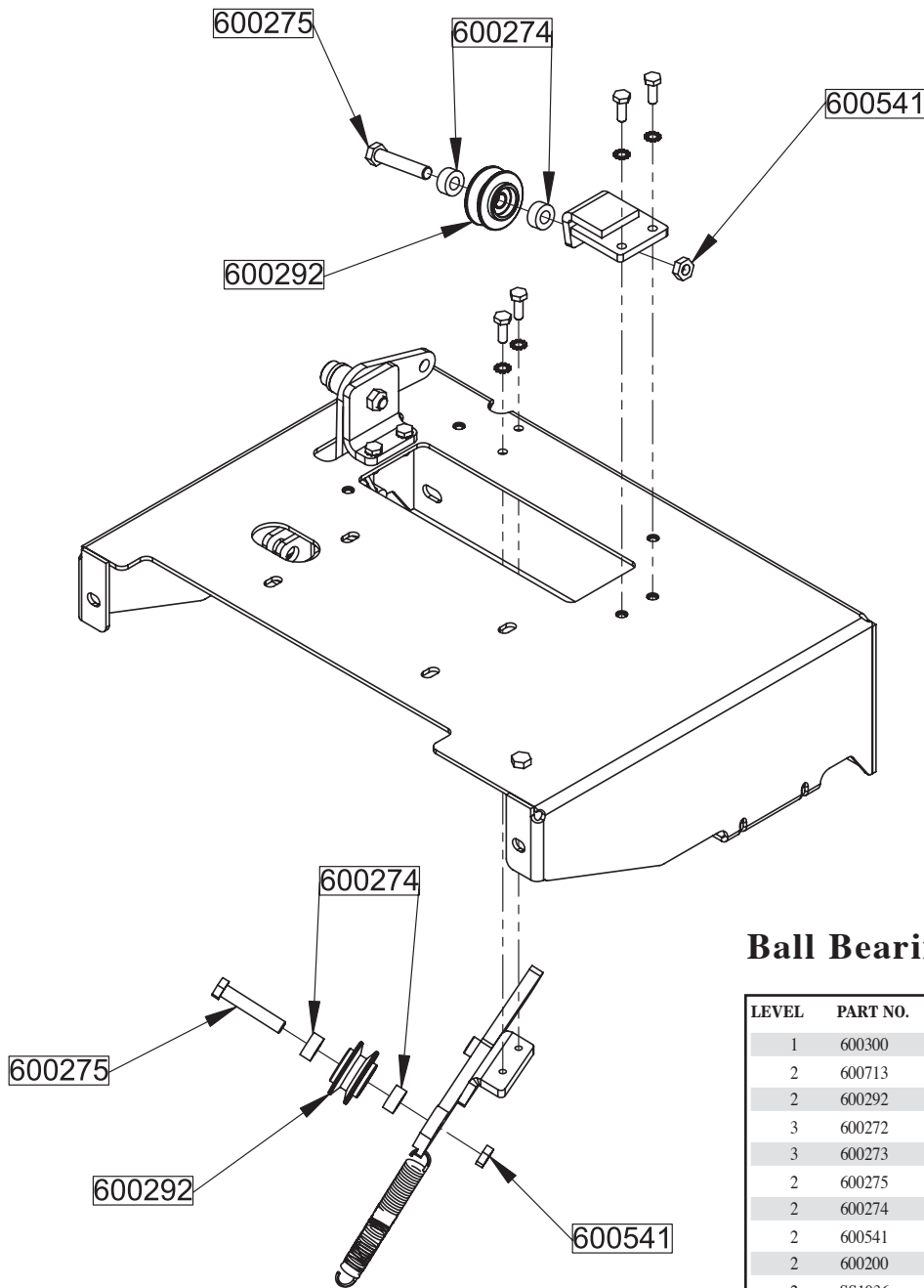

Ball Bearing Pulley Upgrade Kit

LEVEL	PART NO.	DESCRIPTION	QTY.
1	600300	KIT	1
2	600713	INSTRUCTION SHEET	1
2	600292	PULLEY/BEARING ASSEMBLY	2
3	600272	PULLEY, IDLER, FOR BALL BEARINGS	2
3	600273	BEARING, BALL 3/8" X 7/8" 2 SEALS	4
2	600275	BOLT, HEX 3/8-16 X 2" GR5	2
2	600274	SPACER	4
2	600541	NUT, THIN JAM, 3/8-16	2
2	600200	BELT, V, LV W/TRANS	1
2	SS1036	BOX, BALL BEARING UPGRADE KIT	1

LITTLE WONDER®
 DIVISION OF SCHILLER-PFEIFFER, INCORPORATED
 1028 STREET ROAD, P.O. BOX 38
 SOUTHAMPTON, PA 18966
 PHONE 877-596-6337 • FAX 215-357-8045
 877-LWONDER
www.littlewonder.com

P/N 600713
5/06

Specifications, descriptions, and illustrative material in this literature are as accurate as known at the time of publication, but are subject to change without notice.