

STAKE BODY

Swing-Away Mount

for the

LITTLE WONDER® Shredding
TruckLoader
Model 8160

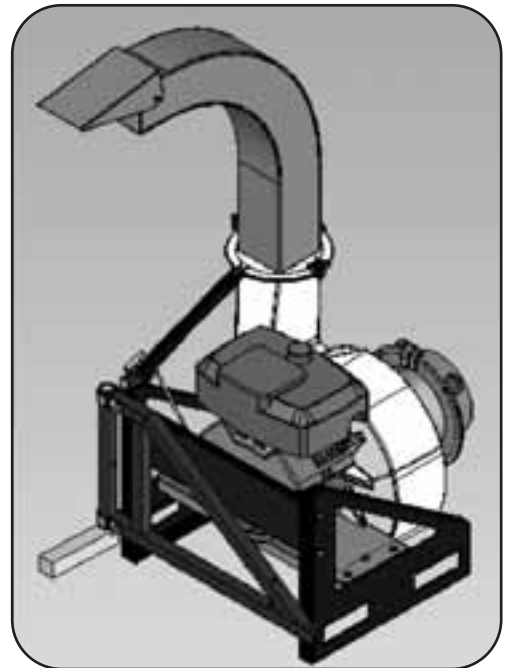
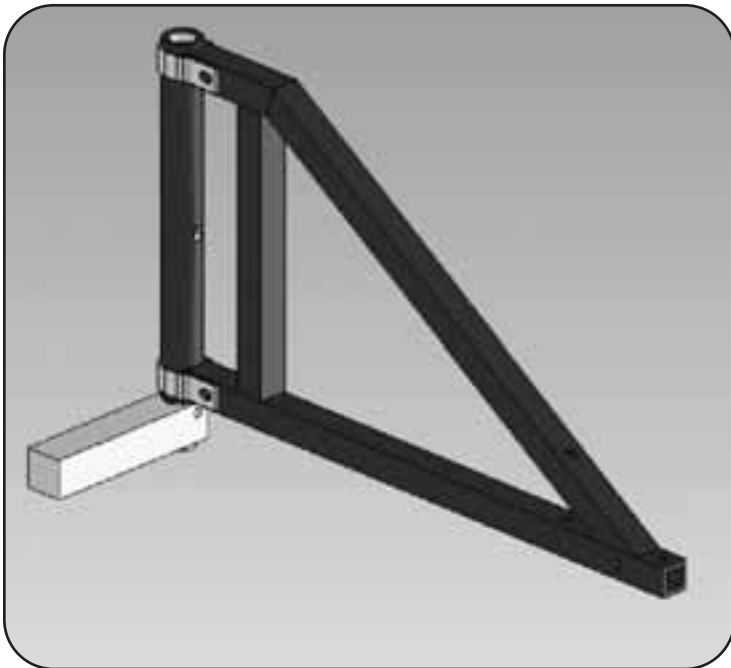

Installation Instructions

720713

Table of Contents

Assembly Instructions	2	Option 1 Exploded View (Wing Nut)	14
Parts & Hardware List	10	Option 2 Exploded View (Lock Pin)	15
Bumper Cut Dimensions	11	Option 3 Exploded View (Hitch Pin and Safety Chain)	16
Option 1 Weld Drawing	12	U-Bolt Hole Location	17
Option 2 & 3 Weld Drawing	13		

Assembly Instructions

STEP 1: Select Latching Option

There are three options for latching the Stake Body Swing-Away in the closed position as depicted in the figures below. Choose one then follow the corresponding installation instructions.

Option 1 (recommended): Bracket and Bumper Bolt with Wing Nut

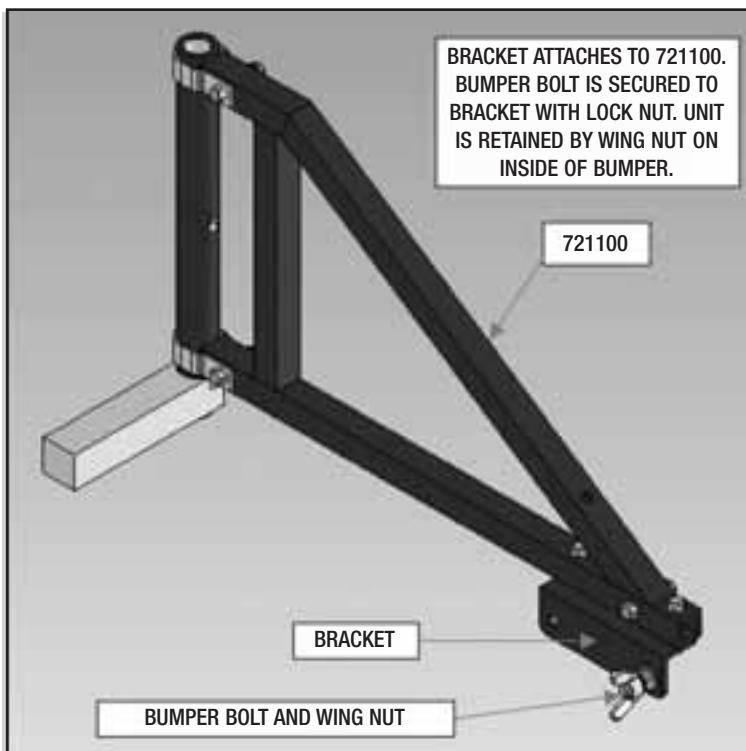

Option 2: Bracket and Vertical Lock Pin

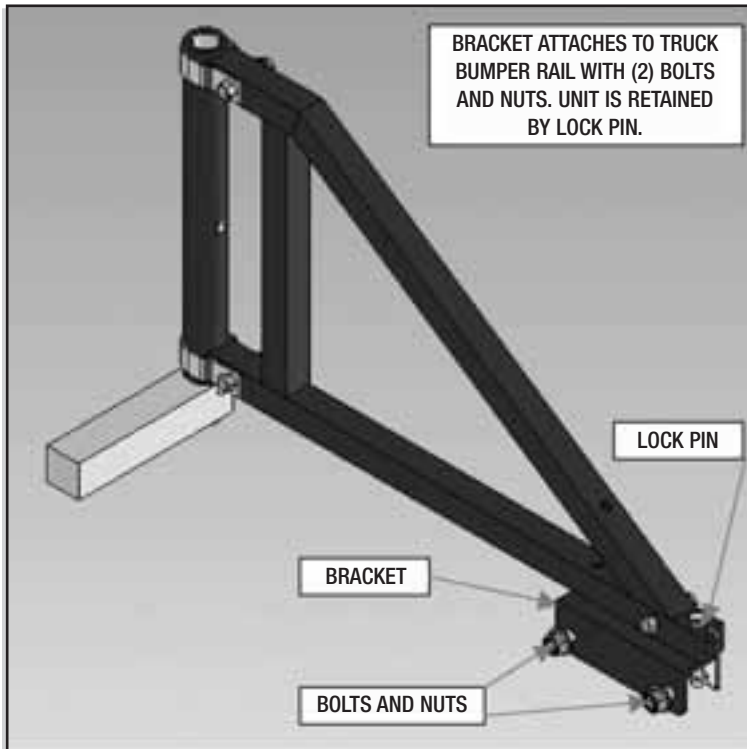

Option 3: Hitch Pin and Safety Chain

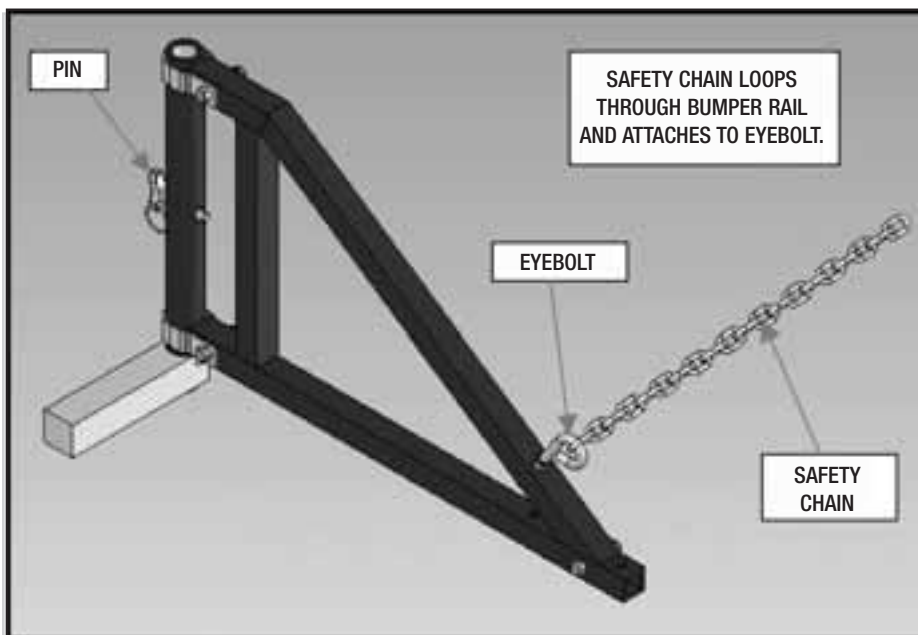

STEP 2: Cut the Bumper Rail to the correct dimensions. Refer to the Bumper Cut Dimensions on page 11.

SHOWN FOR REFERENCE ONLY

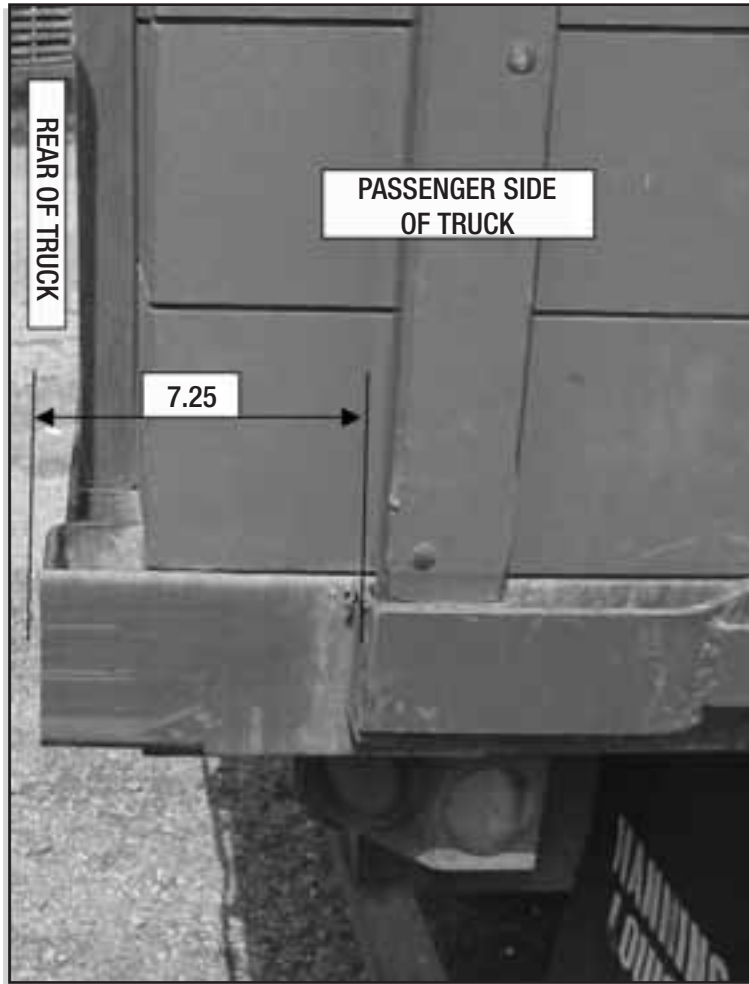

SHOWN FOR REFERENCE ONLY

STEP 3: Position Base Rod Assembly (721101) as shown and weld to side of truck (depends on which option you pick):

STEP 3A (Option 1 position)

Refer to Option 1 Weld Drawing on page 12.

STEP 3B (Options 2 & 3 positions)

Refer to Option 2 & 3 Weld Drawing on page 13.

***STEP 4: Install Thrust Washer (721506) on BASE ROD ASSEMBLY (721101) as shown:
See Exploded Views on pages 14 to 16***

STEP 5: Apply Grease to Shaft of BASE ROD ASSEMBLY (721101).

***STEP 6: Attach SWING-AWAY ASSEMBLY (721100) to the TruckLoader unit as
shown below using the three Nuts (721505) and Bolts (721504) provided:***

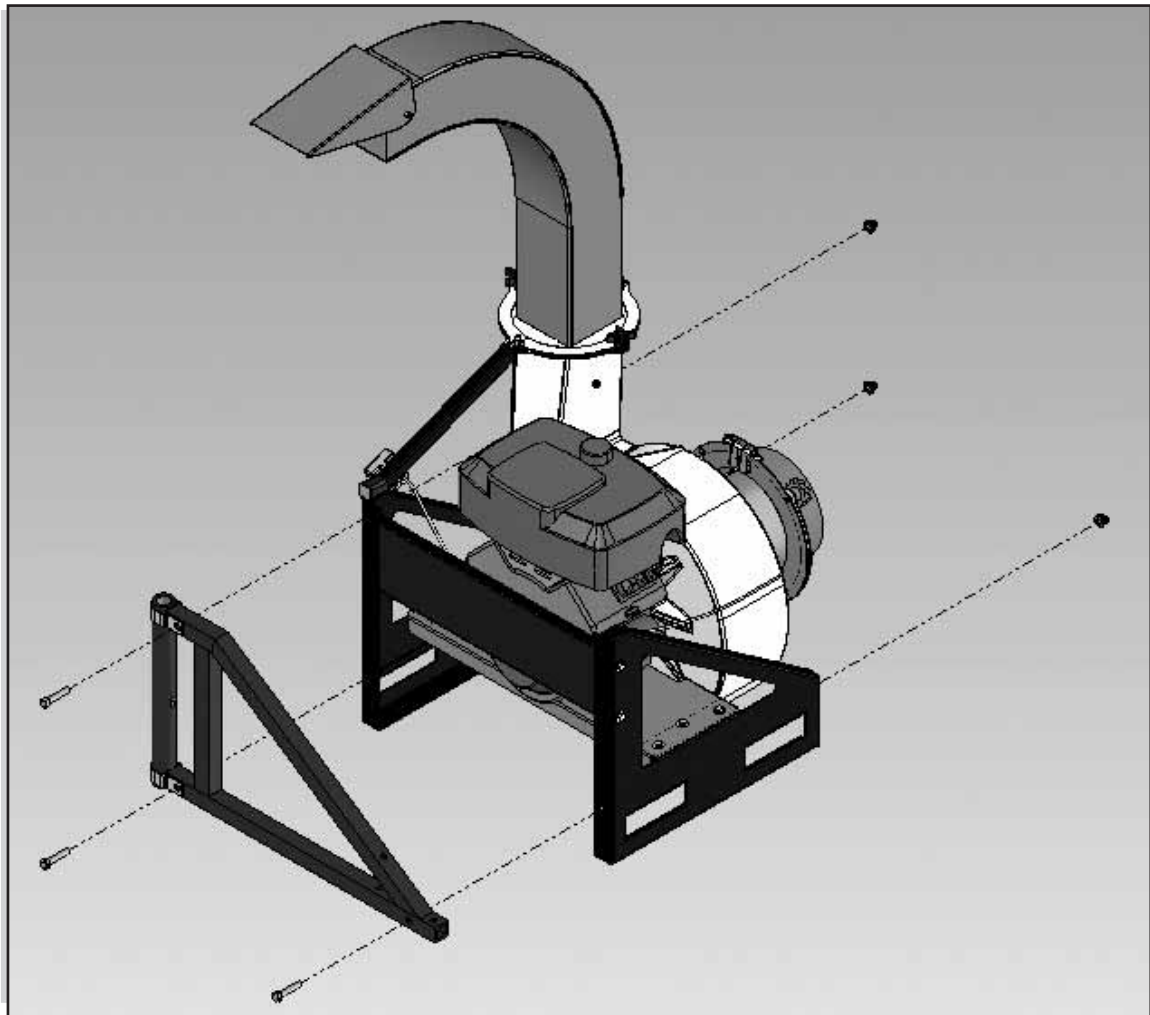

***STEP 7: Mount SWING-AWAY ASSEMBLY (721100) and TruckLoader to
BASE ROD ASSEMBLY (721101) as shown:***

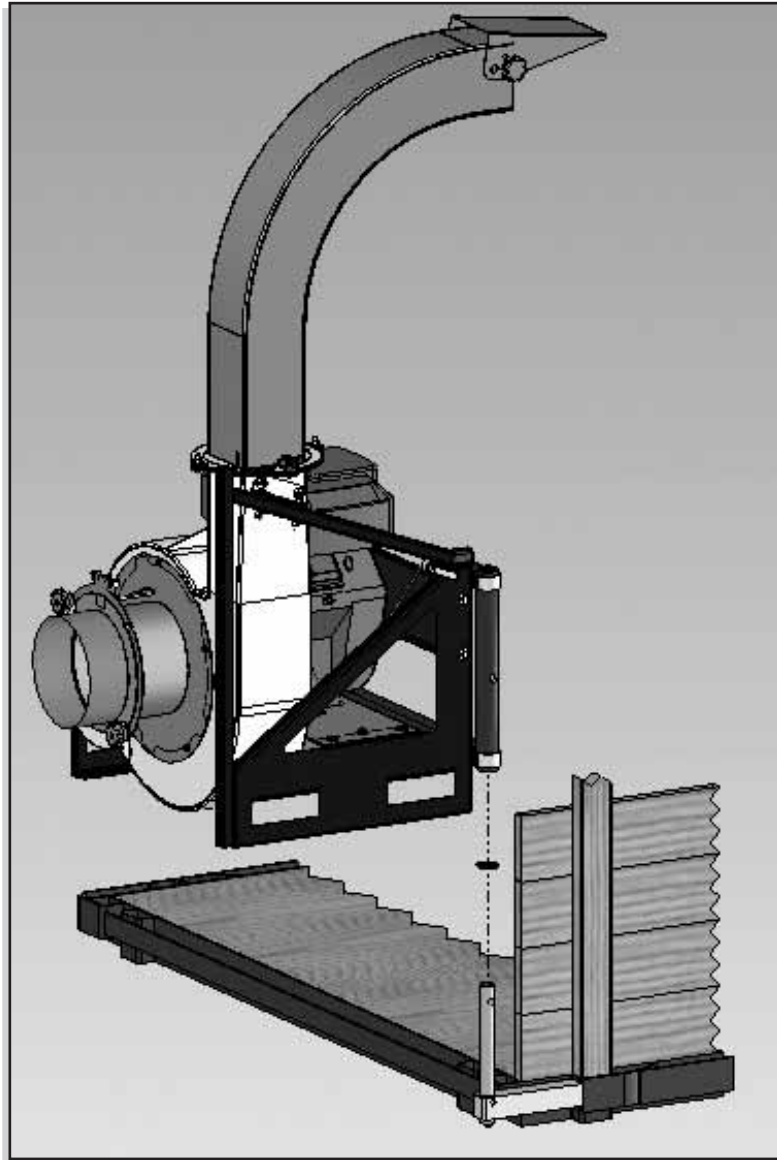

Option 1 Users continue to STEP 8

Option 2 Users continue to STEP 9

Option 3 Users continue to STEP 10

STEP 8: Option 1 Latch Assembly (Bracket and Bumper Bolt with Wing Nut)

Refer to Option 1 Exploded View on page 14

Step 8A:

Attach Bracket (721102) to Swing-Away Assembly (721100) as shown in the diagram using the two bolts and nuts. Refer to Option 1 exploded view.

Step 8B:

Install the Bolt (721510) and Nut (721509) as shown in the exploded view.

Step 8C:

Swing the TruckLoader into the closed position and mark the Bumper Rail for drilling.

Step 8D:

Drill a slightly oversized hole in the Bumper Rail which will accept the 5/8" Bolt (721510) mounted to the Bracket (721102).

Step 8E:

Make sure the bolt can move freely through the hole as the unit is swung.

Step 8F:

Swing the TruckLoader into the closed position and install the Wing Nut (721511) on the 5/8" Bolt (721510).

STEP 9: Option 2 Latch Assembly (Bracket and Vertical Lock Pin)

Refer to Option 2 Exploded View on page 15

Step 9A:

Clamp the Bracket (721102) to the truck's bumper rail such that when the TruckLoader and Swing-Away unit are in the closed position, the 1/2" Diameter hole in the Bracket lines up with the 1/2" Diameter hole in the end of the Swing-Away unit. Refer to Option 2 exploded view.

Step 9B:

Mark the Bumper Rail for two holes to accept the 5/8" Bolts (721508).

Step 9C:

Un-clamp the Bracket (721102) from the Bumper Rail.

Step 9D:

Drill the two holes in the Bumper Rail.

Step 9E:

Bolt the Bracket (721102) to the Bumper Rail using the supplied hardware (721508 and 721509)

Step 9F:

Swing the TruckLoader into the closed position and install the Lock Pin (721104) as shown in the exploded view.

Step 9G:

Connect the Lanyard (721107) to the Lock Pin (721104) via the Split Ring (721117) as shown below.



Step 9H:

Attach the other end of the Lanyard (721107) to nearest bolted connection on the TruckLoader.

STEP 10: Option 3 Latch Assembly (Hitch Pin and Safety Chain)

Refer to Option 3 Exploded View on page 16

Step 10A:

Install the Chain Assembly (721105) as shown in the exploded view using the supplied Nuts (721512). Refer to Option 3 exploded view.

Step 10B:

Attach the Carabiner (720487) to the Chain Assembly as shown in the exploded view.

Step 10C:

Swing the TruckLoader into the closed position and install the Quick Release Pin (721106) as shown in the exploded view.

Step 10D:

Attach the tab end of the Lanyard (721107) to the split ring on the Quick Release Pin (721106).

Step 10E:

Attach the other end of the Lanyard to the nearest bolted connection on the TruckLoader.

Step 10F:

Loop the free end of the Chain Assembly (721105) around the truck's bumper rail and attach it back to itself via the Carabiner (720487).

STEP 11: Open Position Latch

Refer to U-Bolt Hole Location Drawing on page 17 and Figures below

Step 11A:

Drill two holes in the TruckLoader Frame Rail as shown. Refer to UBolt hole drawing.

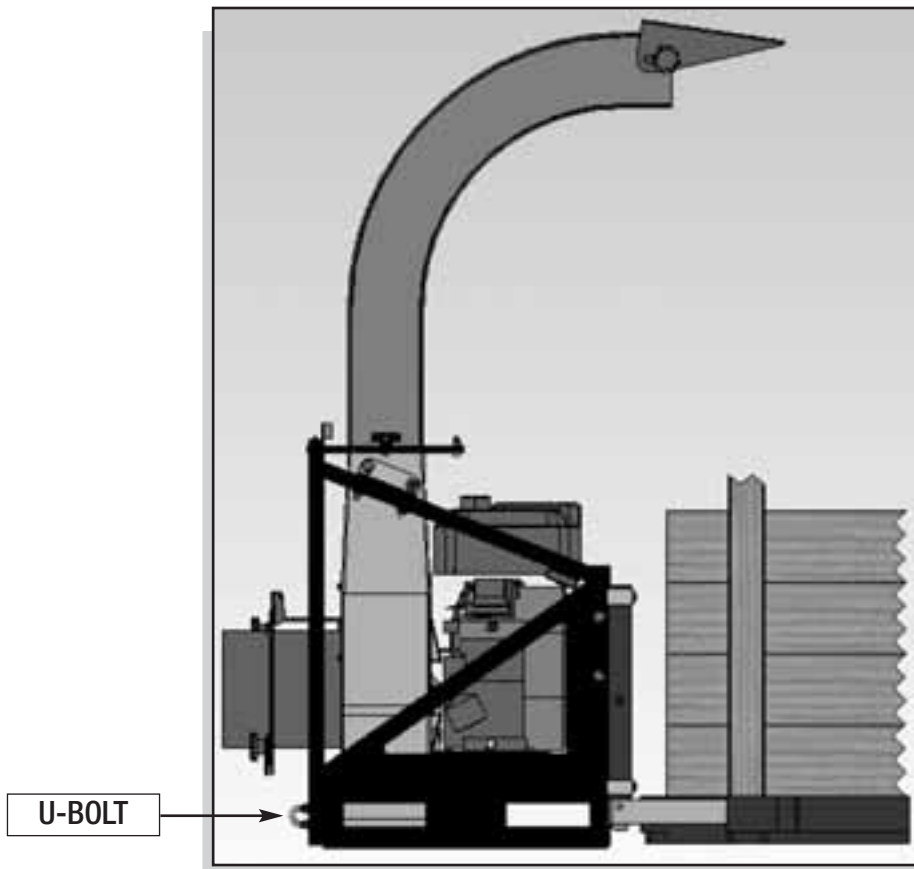

Step 11B:

Slide the U-Bolt (721507) through one of the end links on the Chain (721103) then Install the U-Bolt in the holes drilled in Step 11A using the supplied Nuts (720518).

Step 11C:

Attach the Carabiner (720487) to the other end link of the Chain (721103). See pictures below.

Step 11D:

When in TruckLoader is in the Open Position, the Chain (721103) should loop around the truck's bumper rail and attach back to the UBolt (721507) via the Carabiner (720487). See pictures below.

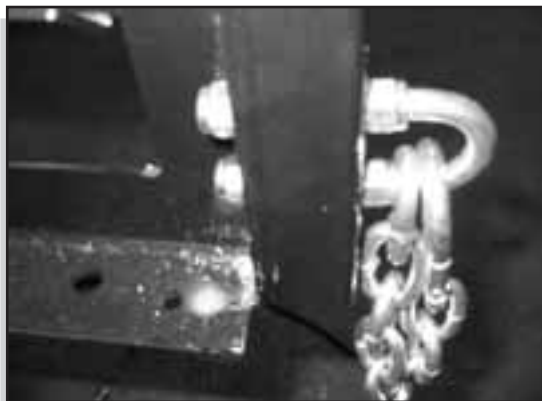

U-Bolt installed on TruckLoader frame



TruckLoader secured in the open position

Stake Body Swing-Away Parts List

Part #	Quantity	Description
721101	1	BASE AND ROD ASSEMBLY
721100	1	SWING-AWAY ASSEMBLY
721102	1	ANGLE BRACKET

Stake Body Swing-Away Hardware

Part #	Quantity	Description
ALL		
721504	5	BOLT HEX 1/2-13 X 2 1/2" LG. GR. 8
721505	5	NUT FLANGE W/LOCK 1/2-13 GR. G
721506	1	THRUST WASHER 1 1/4" I.D. 2" O.D. X 1/8" THK
721507	1	U BOLT 3/8-16 X 3 ZINC
720518	4	3/8-16 NYLOC NUT FOR U BOLT
721103	1	CHAIN 1/4" STEEL 8 LINK LG ZINC
720487	1	CARABINER QUICK CLIP
OPTION 1 ONLY		
721510	1	BOLT HEX 5/8-11 X 2" LG. 18-8 SS
721509	1	5/8-11 DEF. THREAD GR. 8 FLANGE NUT
721511	1	WING NUT W/LOCK 5/8-11 18-8 SS
OPTION 2 ONLY		
721508	2	BOLT HEX 5/8-11 X 1 1/2" LG. GR. 8 ZINC
721509	2	NUT FLANGE W/LOCK 5/8-11 GR. 8 ZINC
721104	1	SAFETY SNAP PIN 1/2 X 3 W/SINGLE WIRE SQ.
721107	1	6" LANYARD ROPE W/LOOP+TAB
721117	1	SPLIT RING
OPTION 3 ONLY		
721105	1	CHAIN 1/4" STEEL LOOP 20 LINKS W/J BOLT
720487	1	CARABINER QUICK CLIP
721512	2	NUT NYLOC 1/2-13 ZINC
721106	1	QUICK RELEASE PIN 1/2 X 2, T-HANDLE
721107	1	6" LANYARD ROPE W/LOOP+TAB
721513		HARDWARE BAG BRICKMAN SWING-AWAY

Cut Dimensions

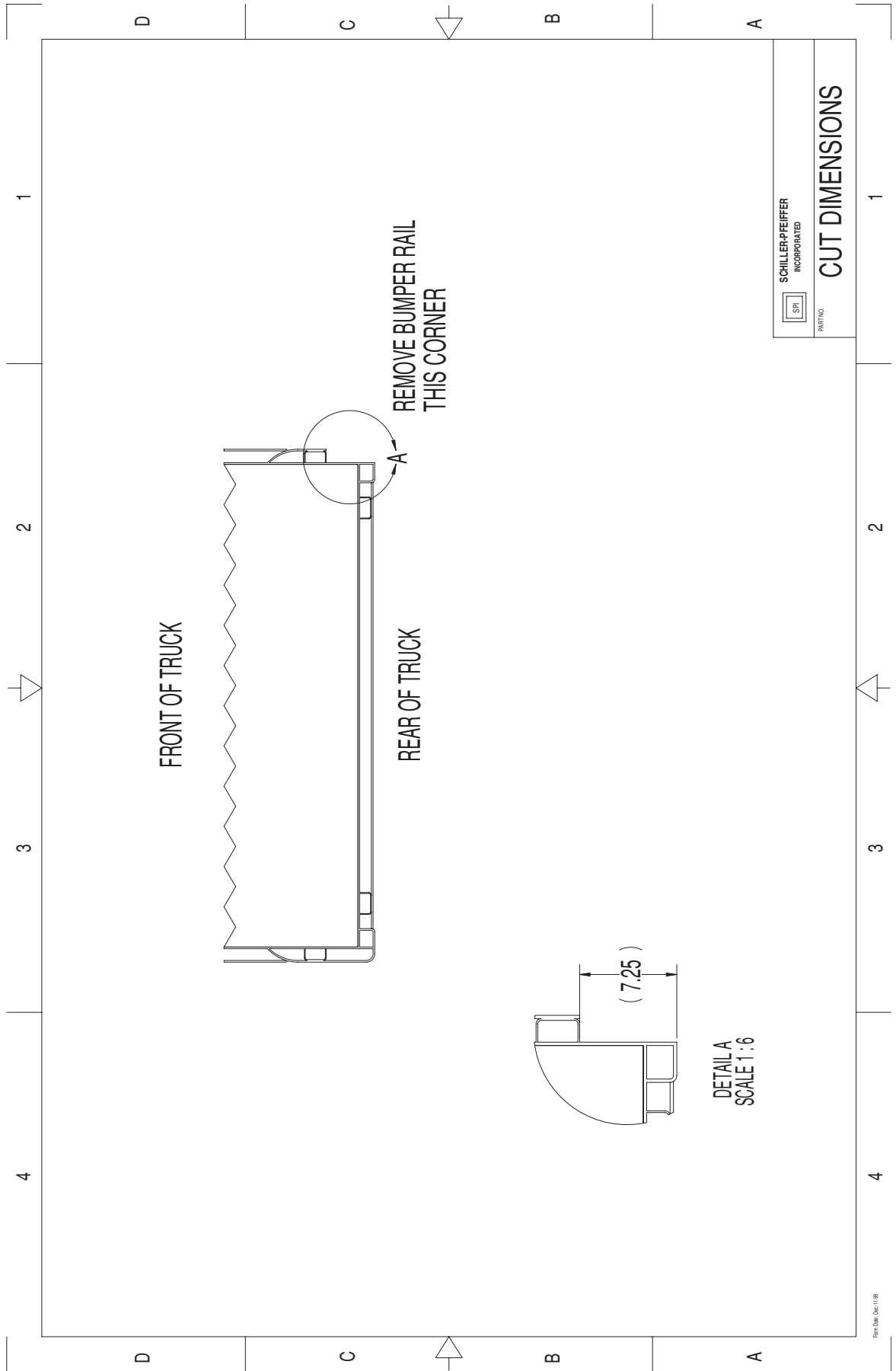

Option 1 Welding

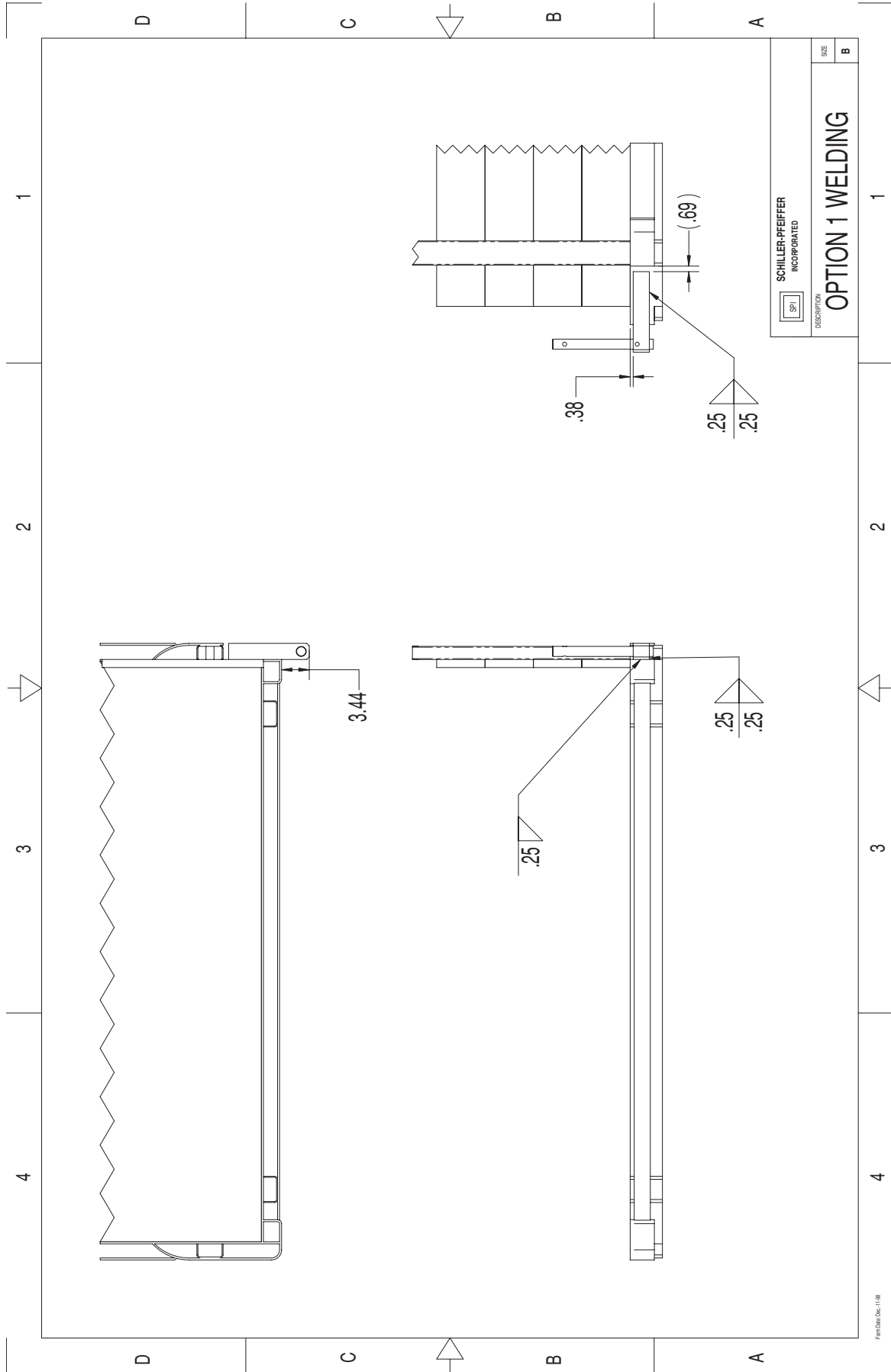

Option 2 & 3 Welding

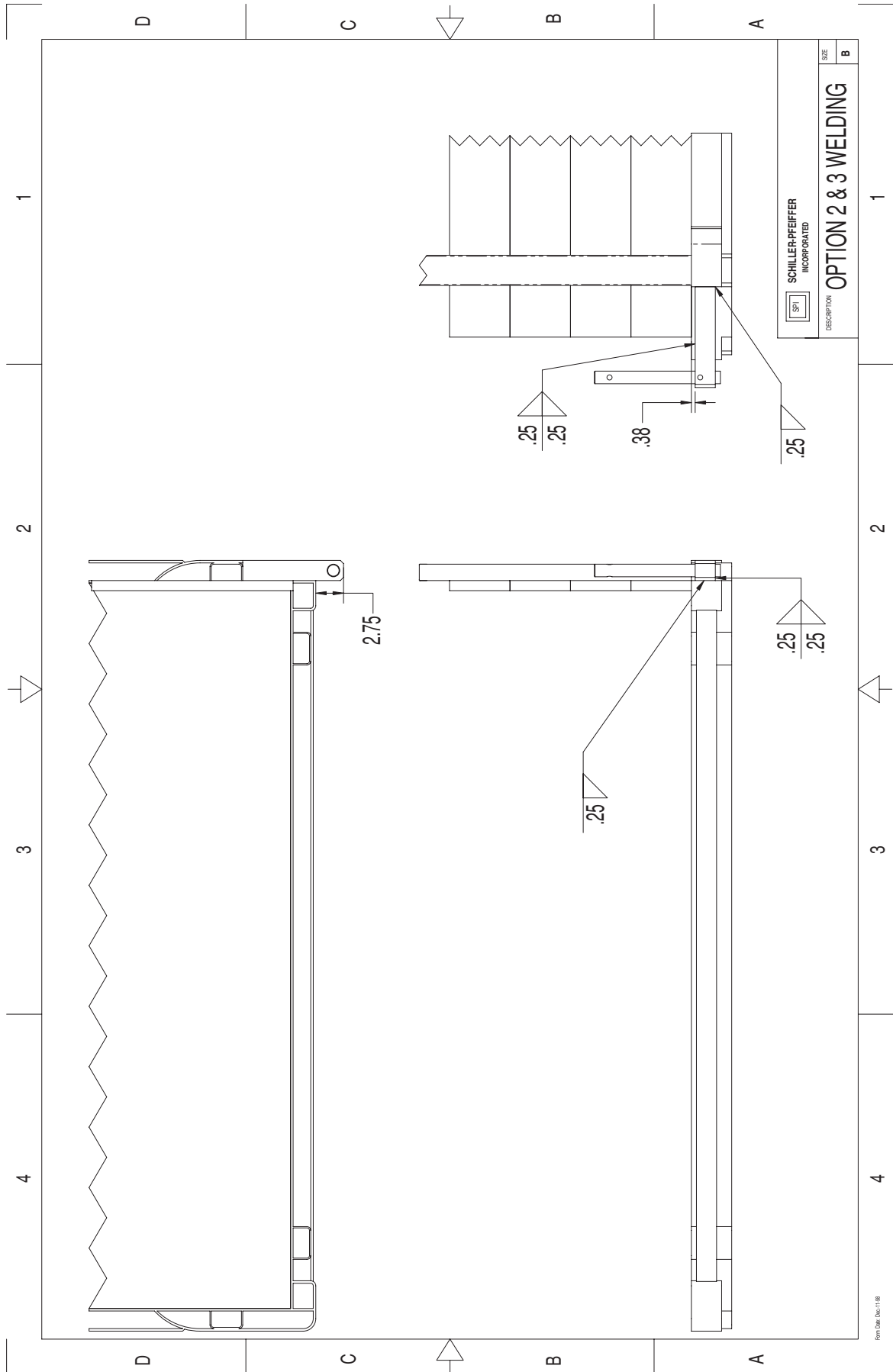

Option 1 Wing Nut

ITEM NO	Part No.	DESCRIPTION	QT
1	721101	BASE AND ROD ASM	1
2	721100	SWING-AWAY ASSEMBLY	1
3	721506	1.25"ID x 2"OD x 1/8" THK THRUST BRACKET	1
4	721102	BRACKET	1
5	721504	1/2-13 x 2.5" LG GRADE 8 HEX BOLT	5
6	721510	5/8-11 x 2" LG GRADE 8 HEX BOLT	1
7	721509	5/8-11 GRADE "G" LOCK NUT	1
8	721505	1/2-13 GRADE "G" LOCK NUT	5
9	721511	5/8-11 WING NUT	1

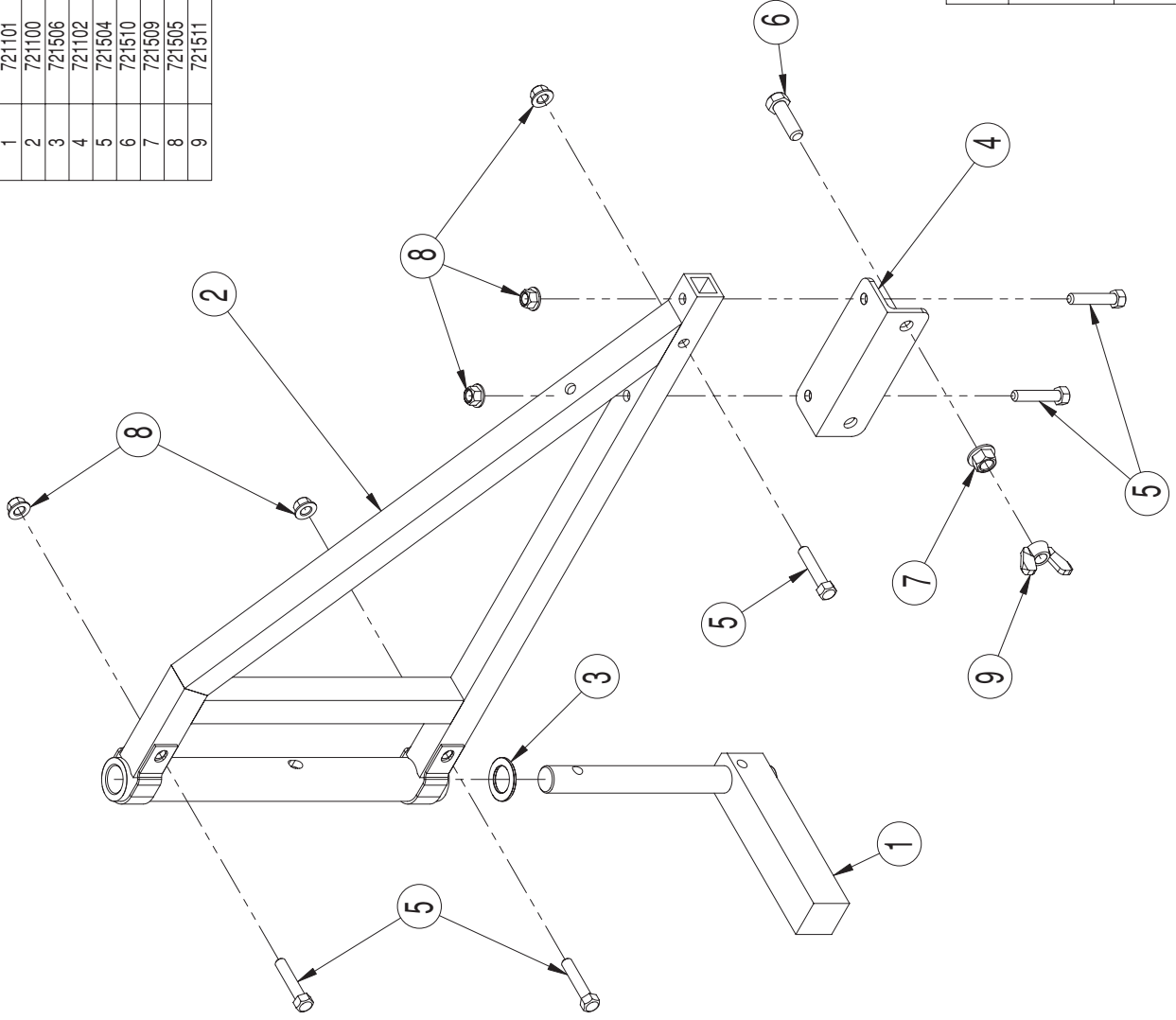

SCHILLER-PFEIFFER
 INCORPORATED

OPTION 1

DESCRIPTION

WING NUT

SIZE

A

Option 2 Lock Pin

ITEM NO.	Part No	DESCRIPTION	QT
1	721101	BASE AND ROD ASM	1
2	721100	SWING-AWAY ASSEMBLY	1
3	721506	1.25"ID x 2"OD x 1/8" THK THRUST WASHER	1
4	721102	BRACKET	1
5	721508	5/8-11 x 1.5" LG GRADE 8 HEX BOLT	2
6	721509	5/8-11 GRADE "G" LOCK NUT	2
7	721104	3" USABLE LG. LOCK PIN	1
8	721504	1/2-13 x 2.5" LG GRADE 8 HEX BOLT	3
9	721505	1/2-13 GRADE "G" LOCK NUT	3
10	721107	LANYARD	1
11	721117	SPLIT RING	1

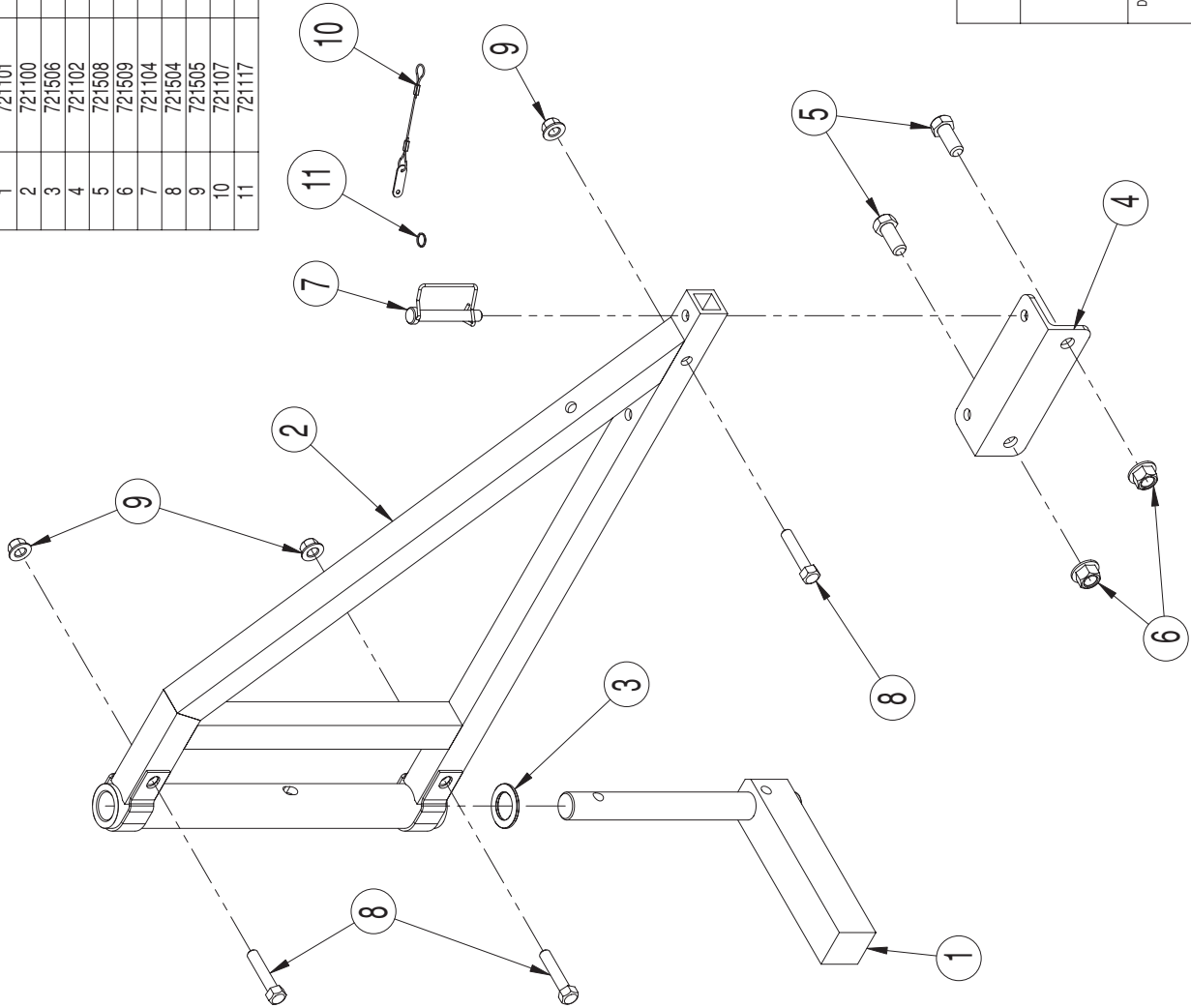

SPI
SCHILLER-PFEIFFER
INCORPORATED

OPTION 2

DESCRIPTION
LOCK PIN

SIZE
A

Option 3 Hitch Pin & Safety Chain

ITEM NO.	Part No	DESCRIPTION	QT
1	721101	BASE AND ROD ASM	1
2	721100	SWING-AWAY ASSEMBLY	1
3	721506	1.25"ID x 2"OD x 1/8" THK THRUST WASHER	1
4	721106	2" USABLE LG QUICK RELEASE PIN	1
5	721504	1/2-13 x 2.5" LG GRADE 8 HEX BOLT	3
6	721505	1/2-13 GRADE "G" LOCK NUT	3
7	721105	CHAIN ASSEMBLY	1
8	721512	NYLON INSERT LOCKNUT, 5/16-18 UNC	2
9	720487	CARABINER QUICK CLIP	1
10	721107	LANYARD	1

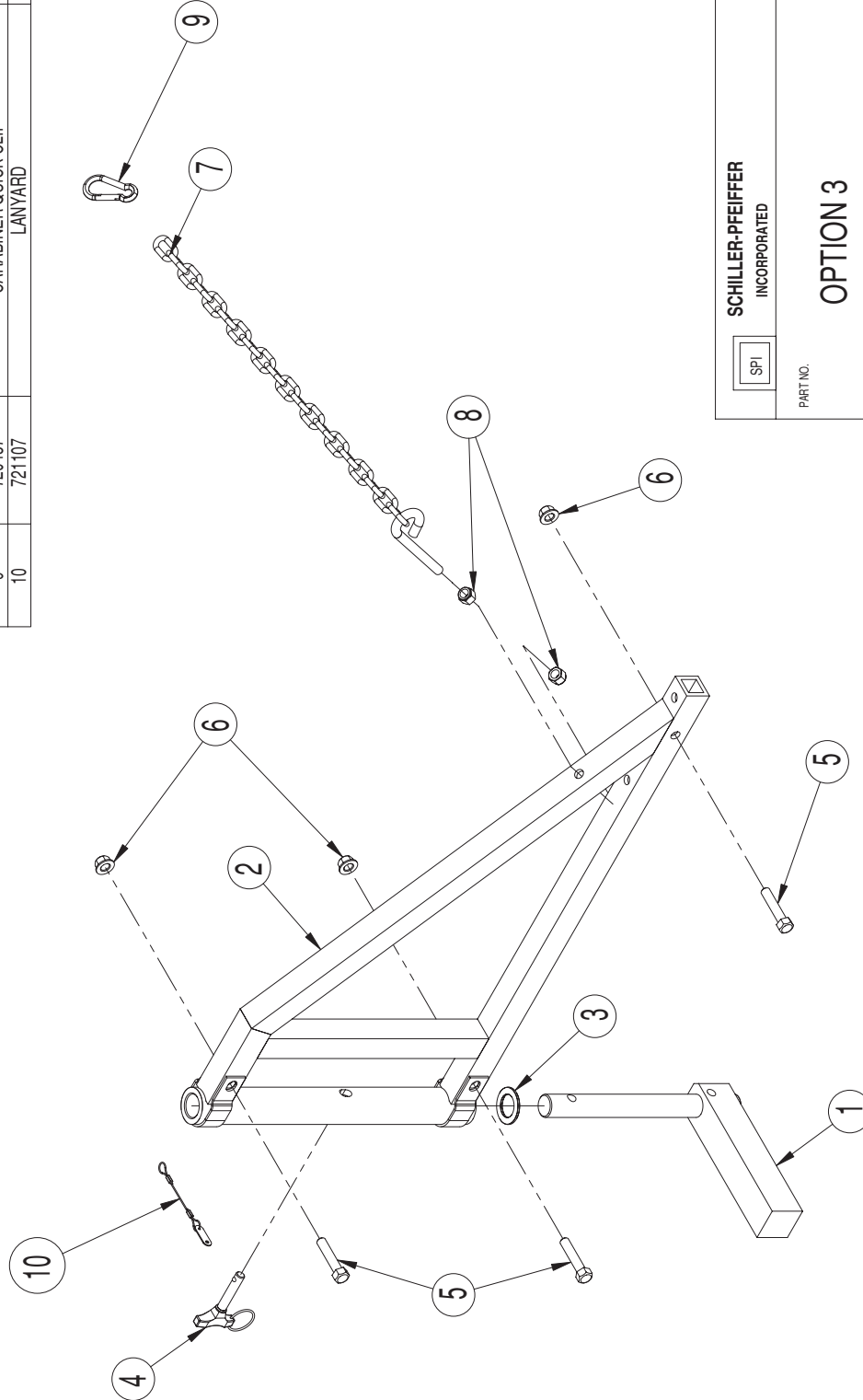

SCHILLER-PFEIFFER
INCORPORATED



PART NO.

OPTION 3

SIZE

A

DESCRIPTION

HITCH PIN & SAFETY CHAIN

U-Bolt Hole Location

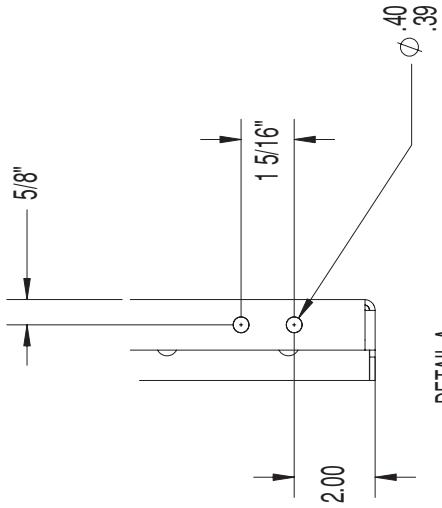
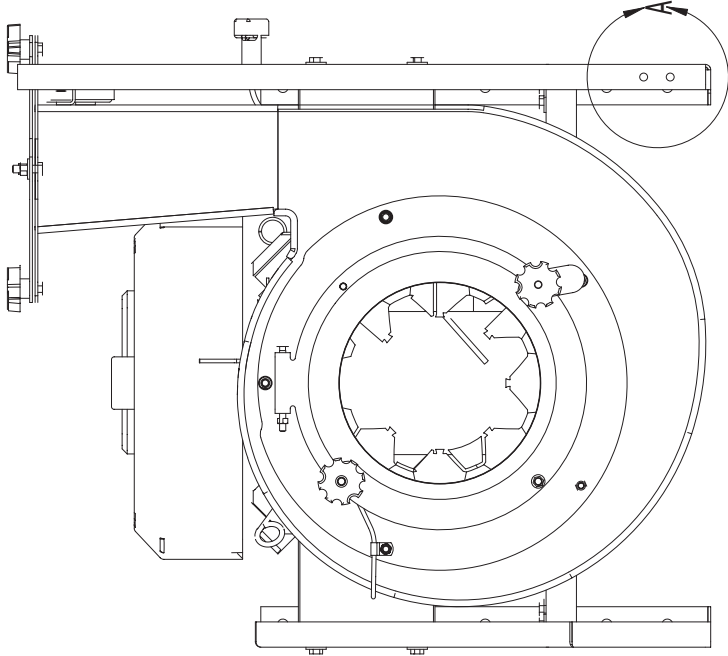

DETAIL A
SCALE 1:4

SPI
SCHILLER-PFEIFFER
INCORPORATED

PART NO. U-BOLT HOLE LOCATION

SIZE	A
------	---

LITTLE WONDER®
DIVISION OF SCHILLER-PFEIFFER, INC.
1028 STREET ROAD, P.O. BOX 38
SOUTHAMPTON, PA 18966
PHONE 877-596-6337 • FAX 215-357-8045
www.littlewonder.com

P/N 720713

9/06