

LITTLE WONDER®

Assembly Instructions for

Crack Cleaning Kit (P/N 6020)

for use with more Little Wonder Edgers

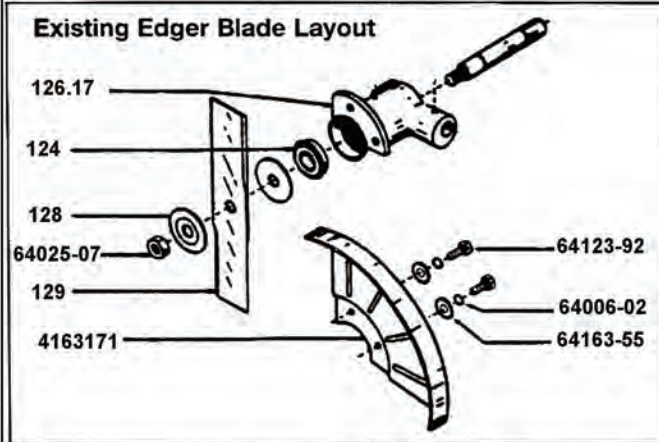

- 1.* Unscrew the two hex head cap screws (P/N 64123-92) from the red cast iron cutter head (P/N 126.17).
- 2.* Remove the two lock washers (P/N 64006-02) and two flat washers (P/N 64163-55).
3. Remove the Blade guard (P/N 4163171).
4. Remove the 1/2 x 20 nut (P/N 64025-07) from the Cutter Head Shaft.
5. Remove one Blade Washer (P/N 128) and the Edger blade (P/N 129).

*Note: These cap screws and washers will be used to attach the enw Brush Guard and complete the assembly. Also keep Blade Washer (P/N 128) and 1/2 x 20 nut (P/N 64025-07). These will be used when the edger blade is reassembled.

After the Blade Guard and Blade have been removed, continue assembly as follows.

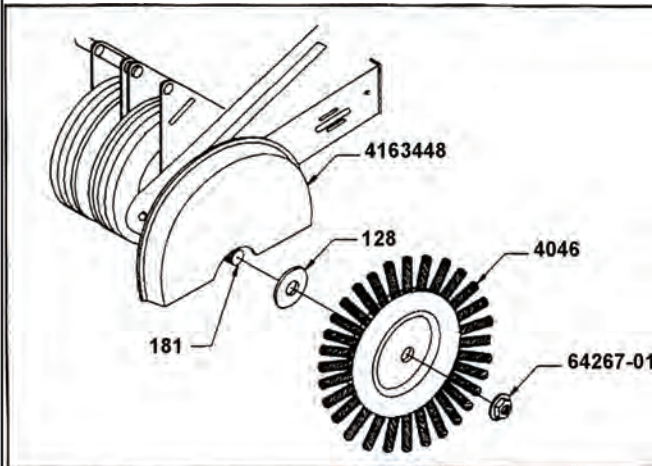

6. Make sure ONE Blade washer (P/N 128) is on the Cutter Head Shaft, and up against the Bearing (P/N 124). The flat side of the Blade Washer (P/N 128) must be facing away from the bearing. the side with the step must be against the bearing.
7. Slide the Wire Hwheel Brush (P/N 4046) onto the Cutter head Shaft.
8. Attach new 1/2 x 20 Flange Nut (P/N 64267-01) onto shaft and tighten.
9. Position the new, fully enclosed Brush Guard (P/N 4163448) over the wire wheel brush (P/N 4046).
10. Align the holes in the Brush Guard (P/N 4163448) with those on the Cutter head (P/N 126.17). Secure with two hex head screws (P/N 64123-92), lock washers (64006-02) and flat washers (P/N 64163-55) that you removed from the Blade Guard (P/N 4163171) in step one.

To reassemble the Edger Blade and Blade Guard, simply reverse the procedure.

Specifications, descriptions, and illustrative material in this literature are as accurate as known at the time of publication, but are subject to change without notice.

LITTLE WONDER®

1028 Street Road

Southampton, PA 18966

Phone: (215) 357-5110 •Fax (215) 357-045